

MOD6 ATHLETIC ASSEMBLY INSTRUCTIONS

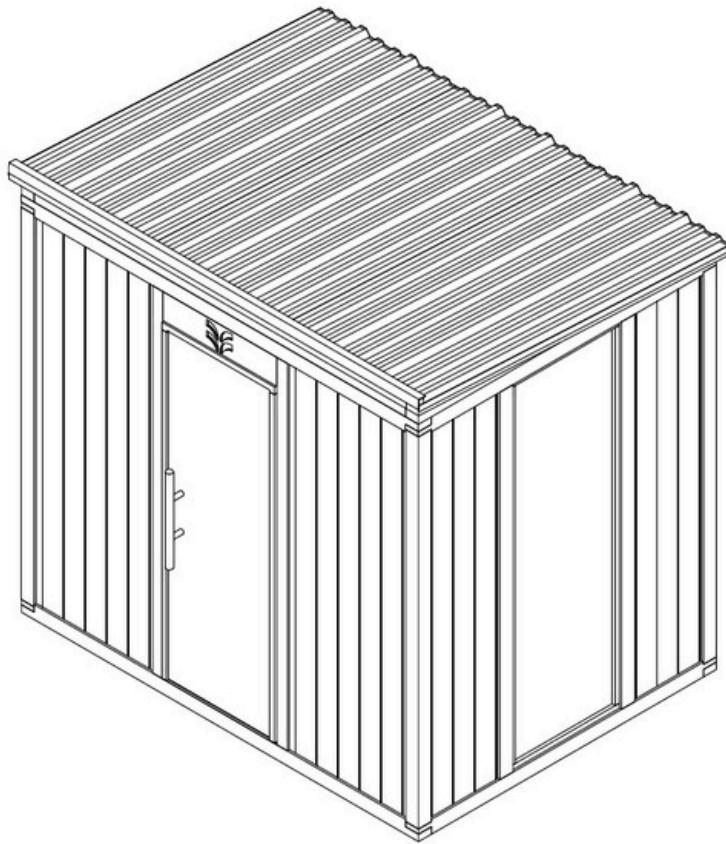

TOOLS & NOTES

REQUIRED TOOLS

- 9/16" SOCKET
- T25 TORX BIT - INCLUDED
- T20 TORX BIT - INCLUDED
- T10 TORX BIT - INCLUDED
- L ADDER

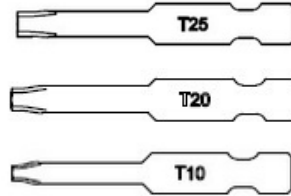

RECOMMENDED TOOLS

- IMPACT DRIVER
- MALLET

SAFETY NOTES

TWO(2) PEOPLE WILL BE NEEDED TO ASSEMBLE THE SAUNA. IT IS RECOMMENDED TO HAVE 3 PEOPLE FOR ASSEMBLY.

SOME PARTS OF THE SAUNA ARE HEAVY. TAKE CARE WHEN LIFTING.

HANDLE THE DOOR AND WINDOWS WITH CARE.

INSTALLATION NOTES

ALL THE POSTS, BEAMS, & PANELS ARE LABELED TO WHERE THEY NEED TO BE INSTALLED. SOME PARTS MAY LOOK DIFFERENT THAN WHAT IS SHOWN IN THIS MANUAL.

CONSULT YOUR HEATER MANUAL AND MOD6 LAYOUT PLAN BEFORE BUILDING AS YOU WILL NEED TO PLAN WHERE TO RUN THE WIRES FOR AN ELECTRIC HEATER.

A CERTIFIED ELECTRICIAN SHOULD INSTALL THE ELECTRIC HEATER AND ANY OTHER ELECTRONICS SUCH AS LIGHTING.

ASSEMBLY INSTRUCTIONS

THE MOD6 IS DESIGNED TO BE INSTALLED CLOCKWISE STARTING FROM THE DOOR. PANELS SHOULD FIT SNUGLY AND MAY REQUIRE SOME GENTLE MANIPULATION TO FIT PROPERLY IN PLACE

STEP 1

LAYOUT THE BEAMS IN THE CONFIGURATION SHOWN BELOW. MAKE SURE THE CHANNEL WITH HOLES ARE ON THE OUTER SIDE OF THE BEAMS THEN INSERT THE PEGS.

ONCE THE BEAMS ARE IN PLACE, YOU WILL NEED TO START RUNNING WIRES FOR THE HEATER AND OTHER ITEMS REQUIRING POWER (e.g. HEATER CONTROLLER, LIGHTING). PLEASE MAKE SURE TO LEAVE ENOUGH WIRE LENGTH TO RUN THE WIRING UP THE POSTS LATER.

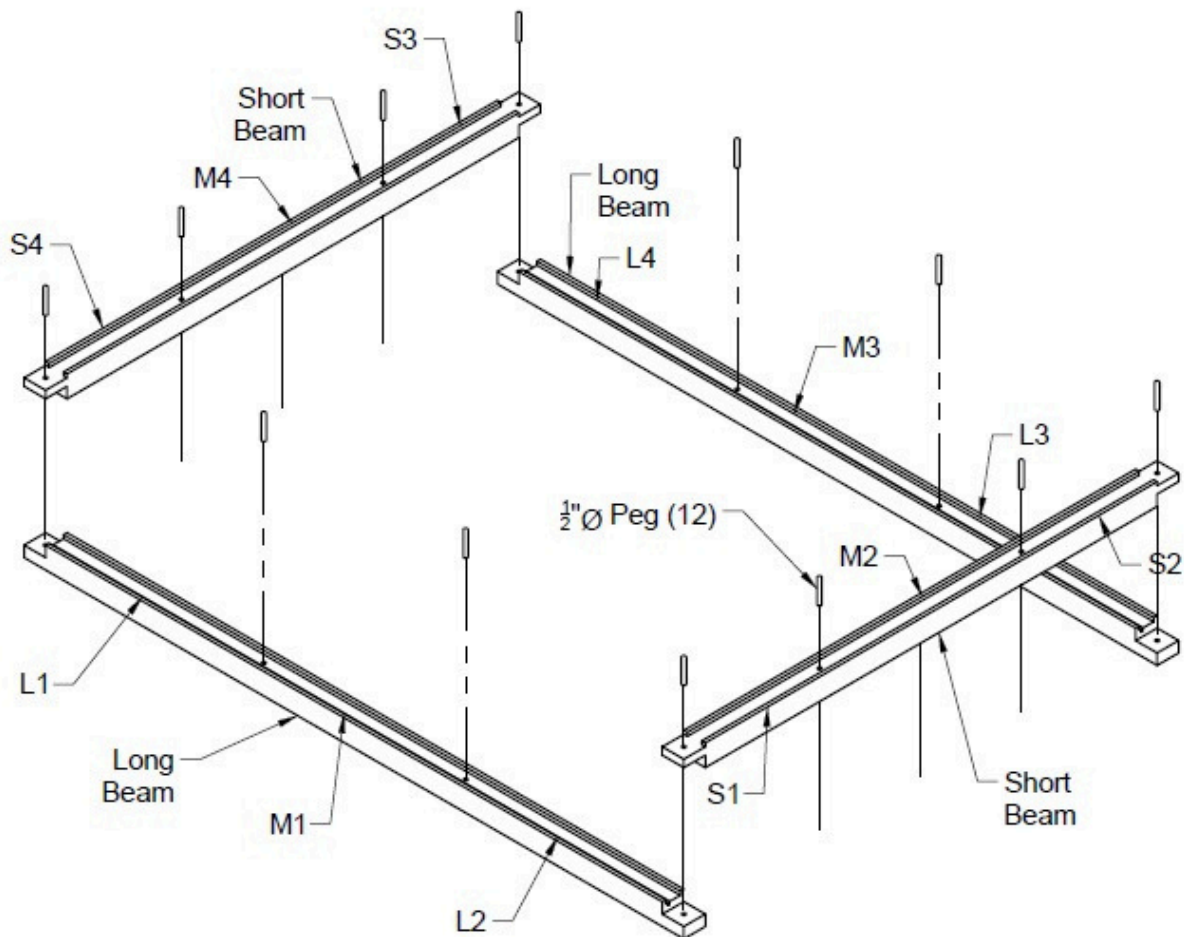

STEP 2

CAREFULLY LOWER THE DOOR ONTO THE TWO CENTER PEGS OF THE SIDE SHOWN ON YOUR LAYOUT DIAGRAM. (M1 IS USED IN THIS DIAGRAM FOR DEMONSTRATION PURPOSES).

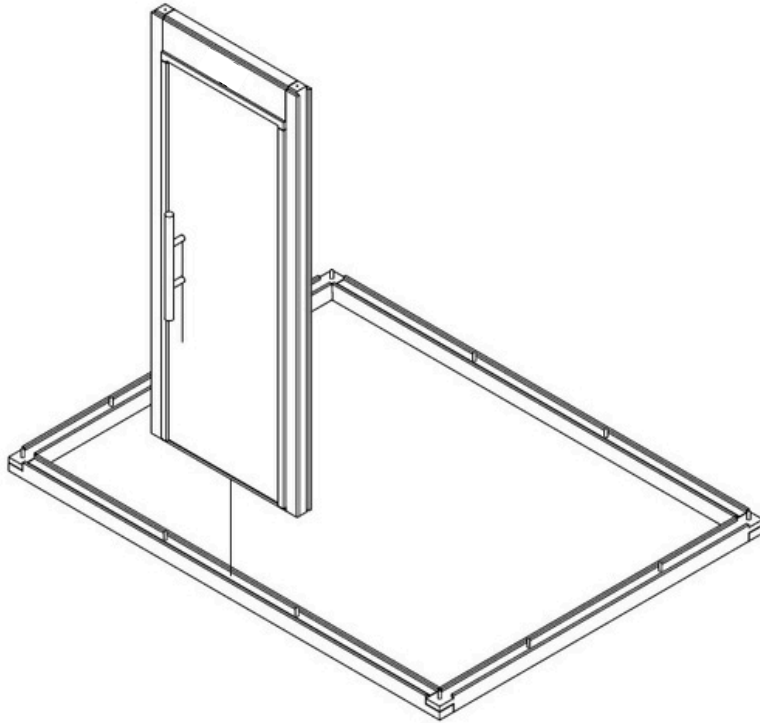

STEP 3

MOVING CLOCKWISE FROM THE DOOR, SLIDE THE PANEL INTO PLACE. THE PANELS WILL BE MARKED DESIGNATING WHERE THEY SHOULD BE INSTALLED BASED ON YOUR SPECIFIC LAYOUT.

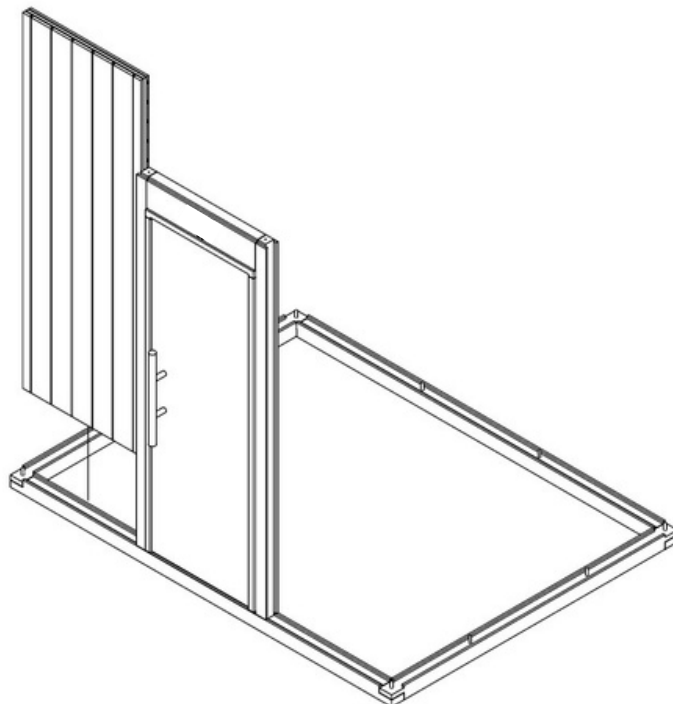

NOTE: MAKE SURE TO RUN WIRES UP POSTS AS NEEDED FOR YOUR HEATER OR OTHER ELECTRICAL APPLICATIONS. ALSO MAKE SURE WIRES ARE NOT GETTING PINCHED BY PANELS OR POSTS AS THEY ARE INSTALLED.

STEP 4

INSERT CORNER POST

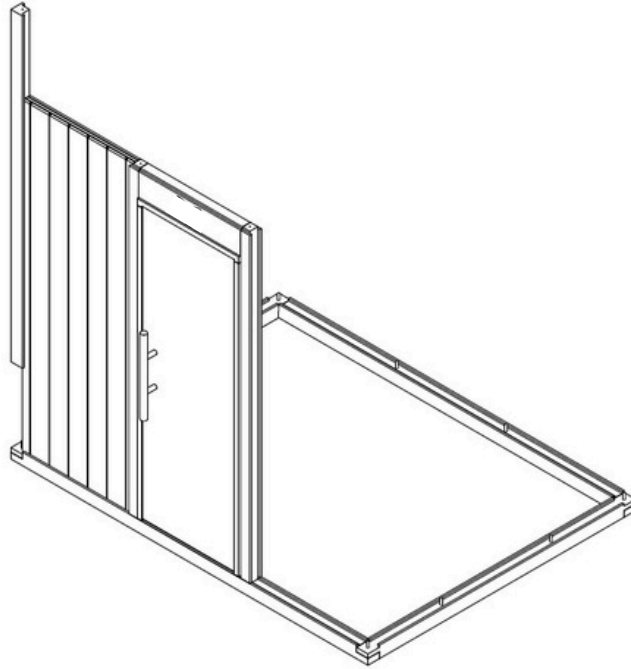

STEP 5

SLIDE PANEL INTO POSITION.

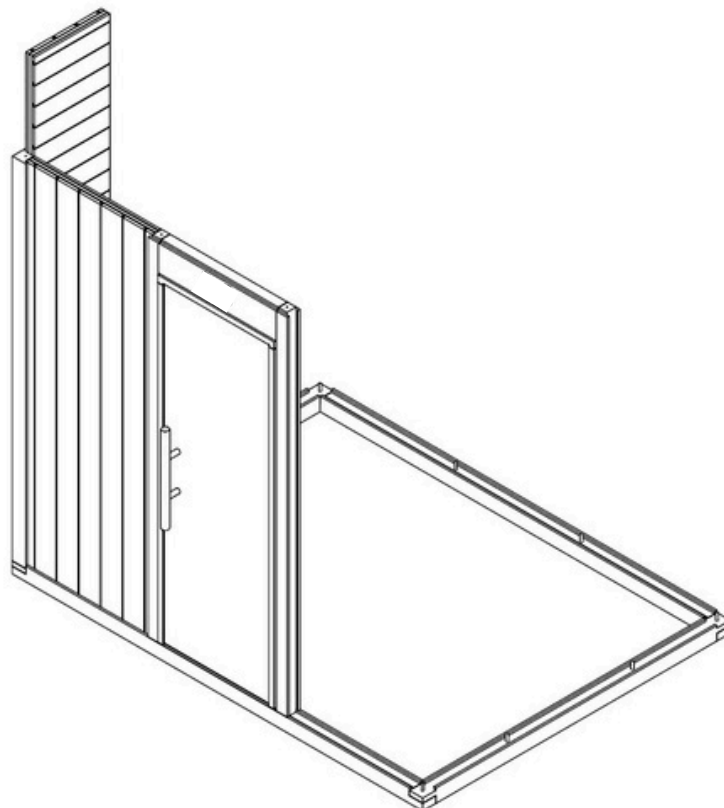

STEP 6

INSERT POST ON TO THE PEG NEXT TO THE PANEL.

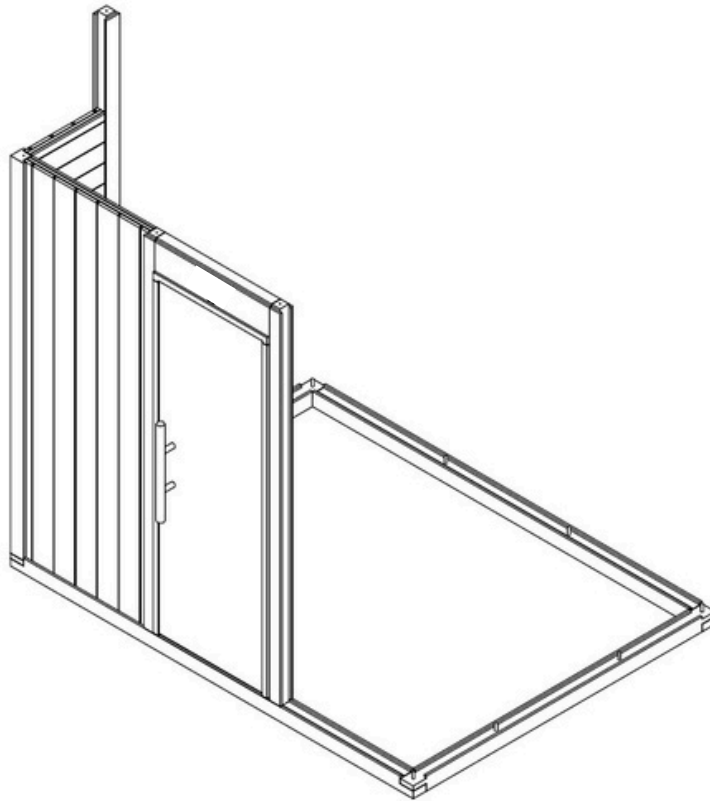

STEP 7

CONTINUE WORKING AROUND THE SAUNA, INSTALLING POSTS AND PANELS.

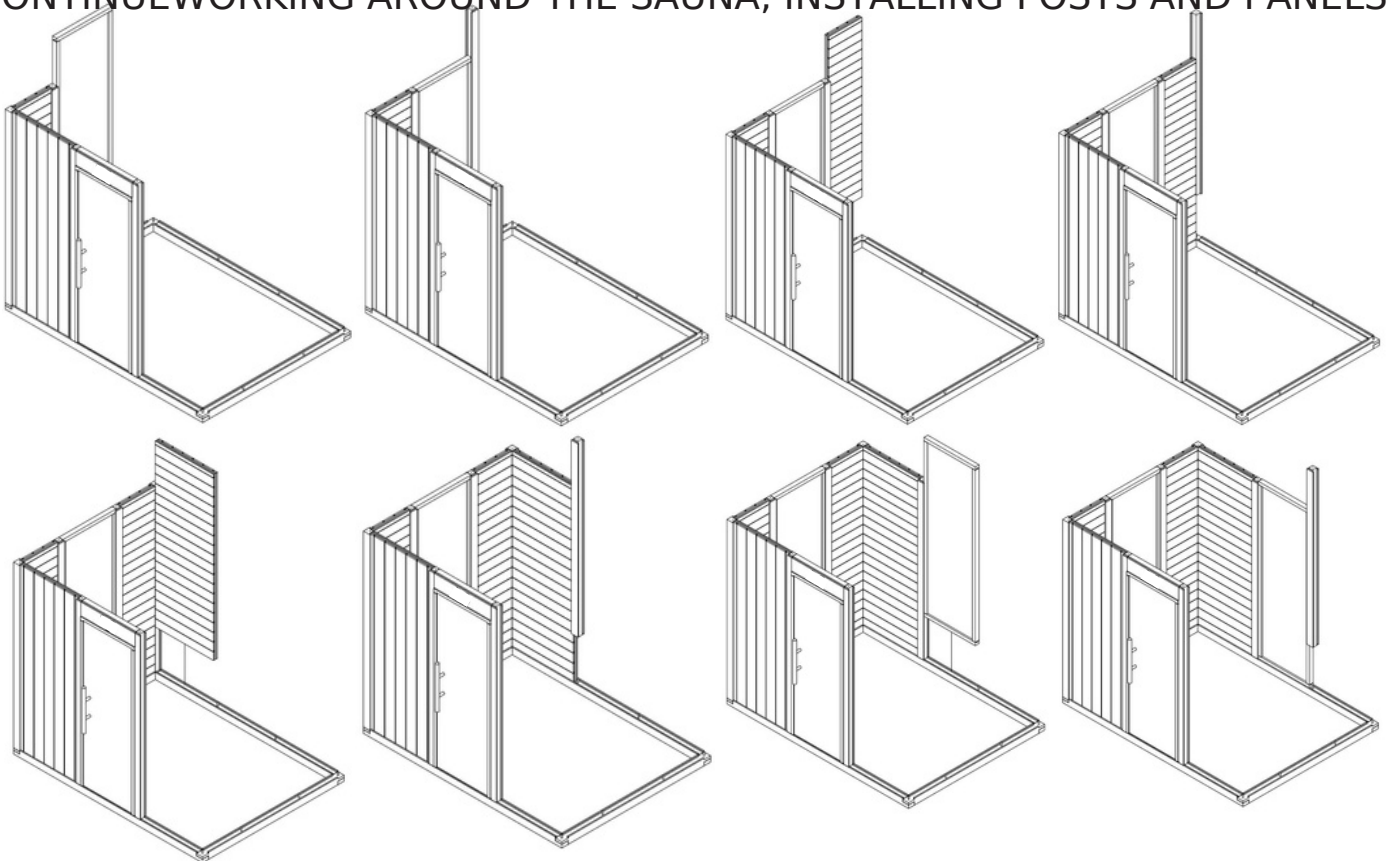

STEP 7 CONT.

CONTINUE WORKING AROUND THE SAUNA, INSTALLING POSTS AND PANELS.

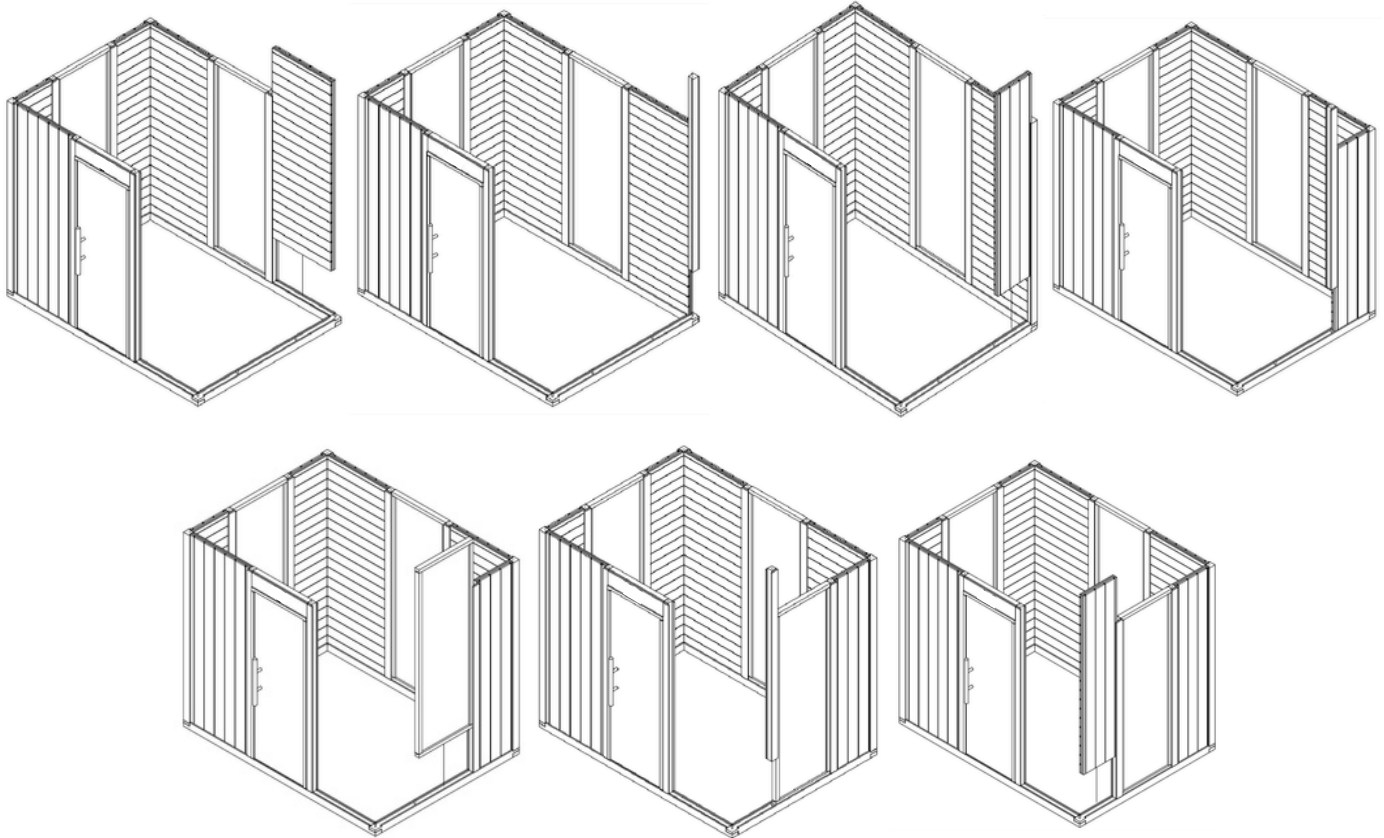

NOTE: IF YOU HAVE A WOODHEATER BUMBOUT, ONE OF THE 'M' PANEL AREAS WILL BE OPEN AND 2 MIDDLE POSTS WILL ONLY BE CUT ON ONE SIDE.

STEP 8

ONCE THE SECOND TO LAST PANEL IS INSTALLED, INSTALL THE FINAL PANEL BEFORE THE LAST CORNER POST.

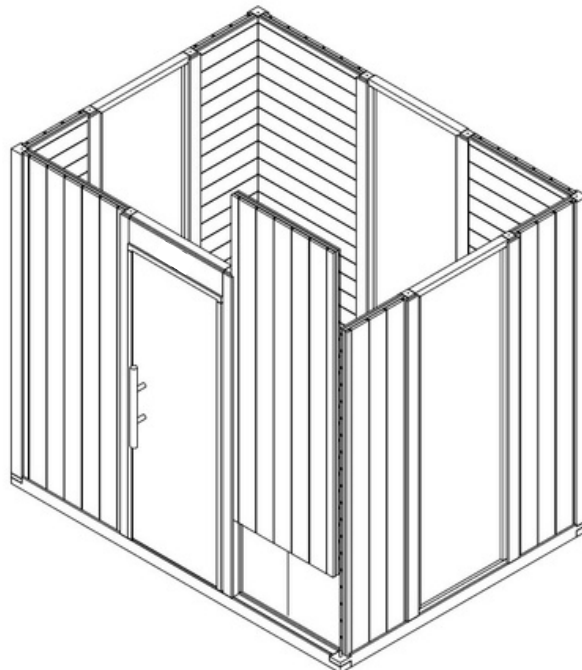

STEP 9

INSTALL THE FINAL CORNER POST

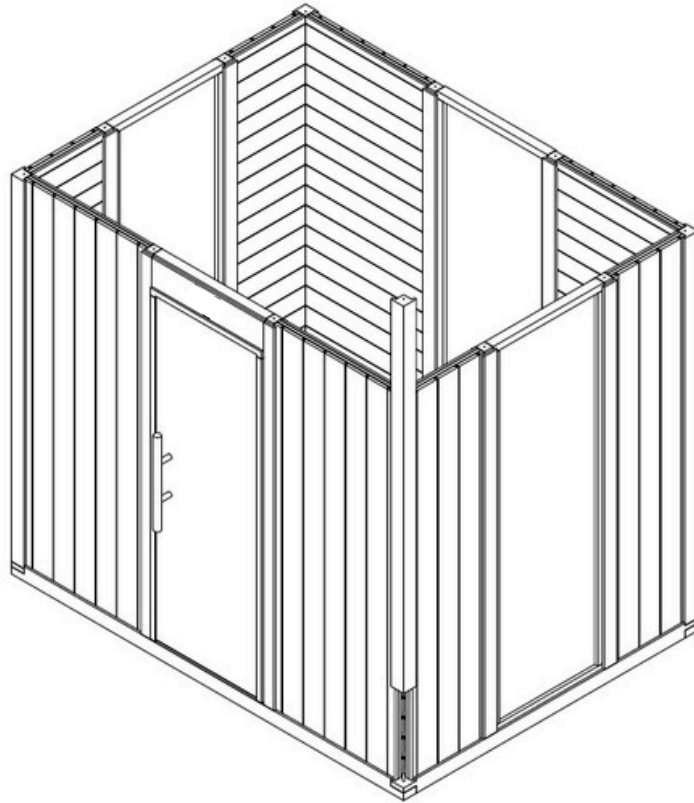

STEP 10

BEFORE MOVING FORWARD CHECK TO MAKE SURE ALL YOUR PANELS AND ANY WIRING ARE IN THEIR PROPER LOCATIONS. INSTALL THE TOP SHORT BEAMS.

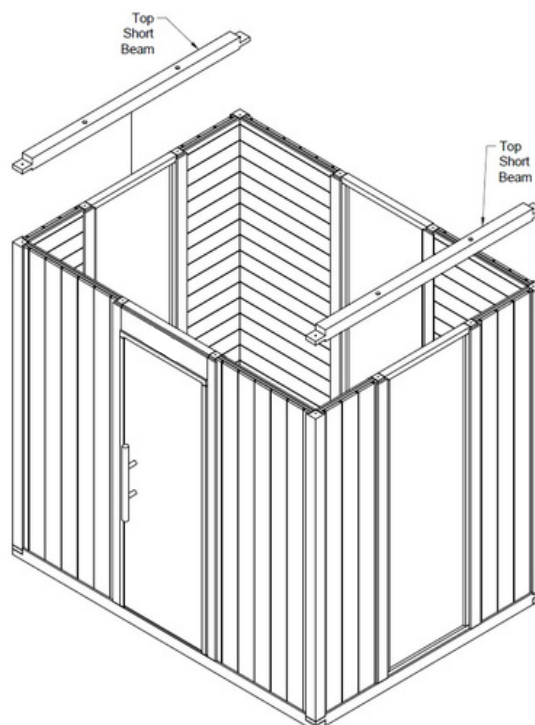

STEP 11

INSTALL THE TOP LONG BEAMS. MAKE SURE ALL THE PANELS ARE COMPLETELY INSIDE THE BEAM SLOT.

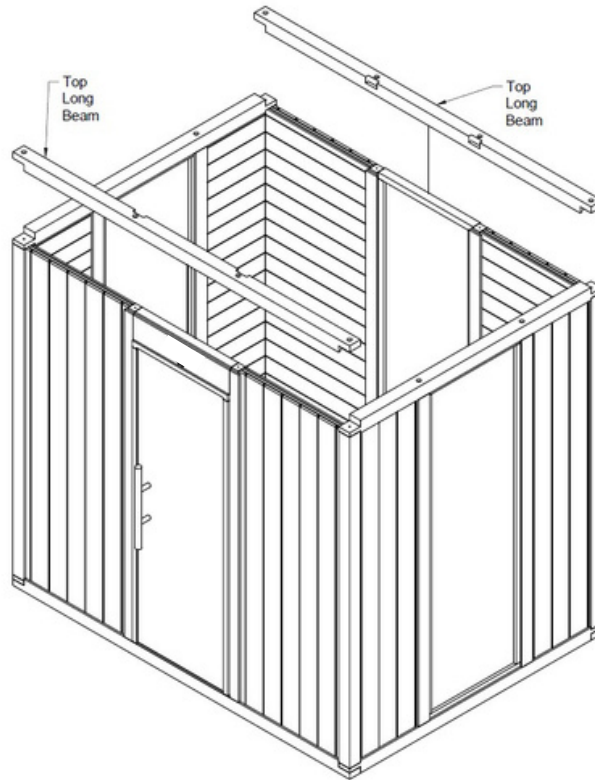

STEP 12

WORK AROUND THE TOP OF THE SAUNA, BOLTING DOWN THE LAG BOLTS. IT IS RECOMMENDED TO USE AN IMPACT DRIVER AND FINISH TIGHTENING WITH A SOCKET WRENCH.

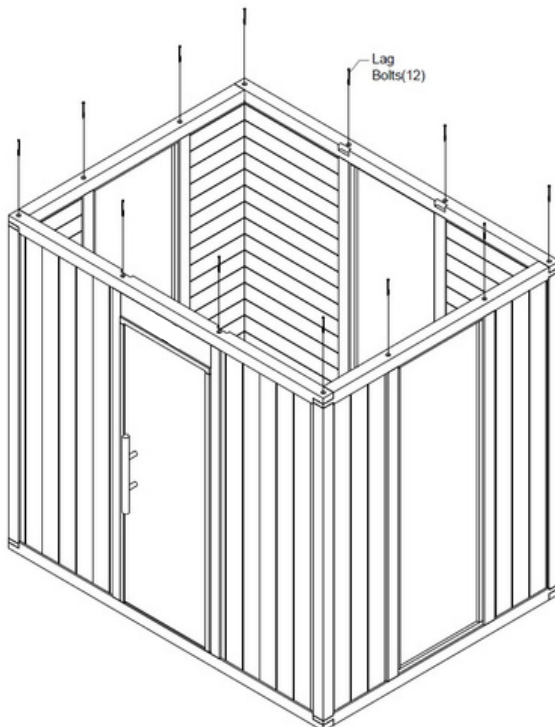

THE LAG BOLTS ARE 9/16"



STEP 13

INSTALL INSIDE TRIM IN THAT CORNER USING THE TRIM TORX SCREWS AND THE T10 TORX BIT.

NOW WOULD BE THE BEST TIME TO HAVE THE ELECTRICIAN INSTALL THE HEATER AND ANY OTHER ELECTRONICS.

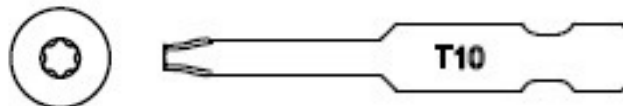

STEP 14

INSTALL THE CEILING BEAMS BY INSERTING THEM INTO THE NOTCHES ON THE TOP LONG BEAMS AND THEN SCREWING THEM DOWN.

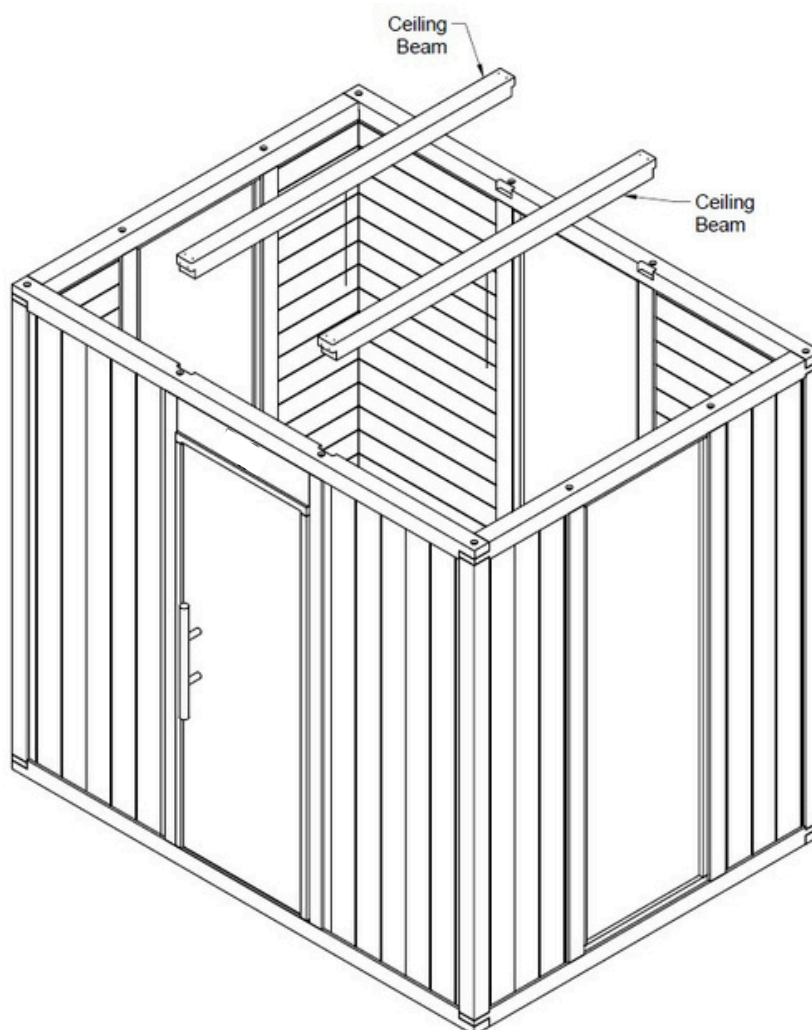

THE SCREWS ARE 3" TORX SCREWS. USE THE T25 TORX BIT.

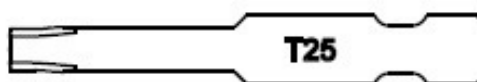

STEP 15

INSERT THE CEILING PANELS INTO THEIR RESPECTIVE SPOTS.

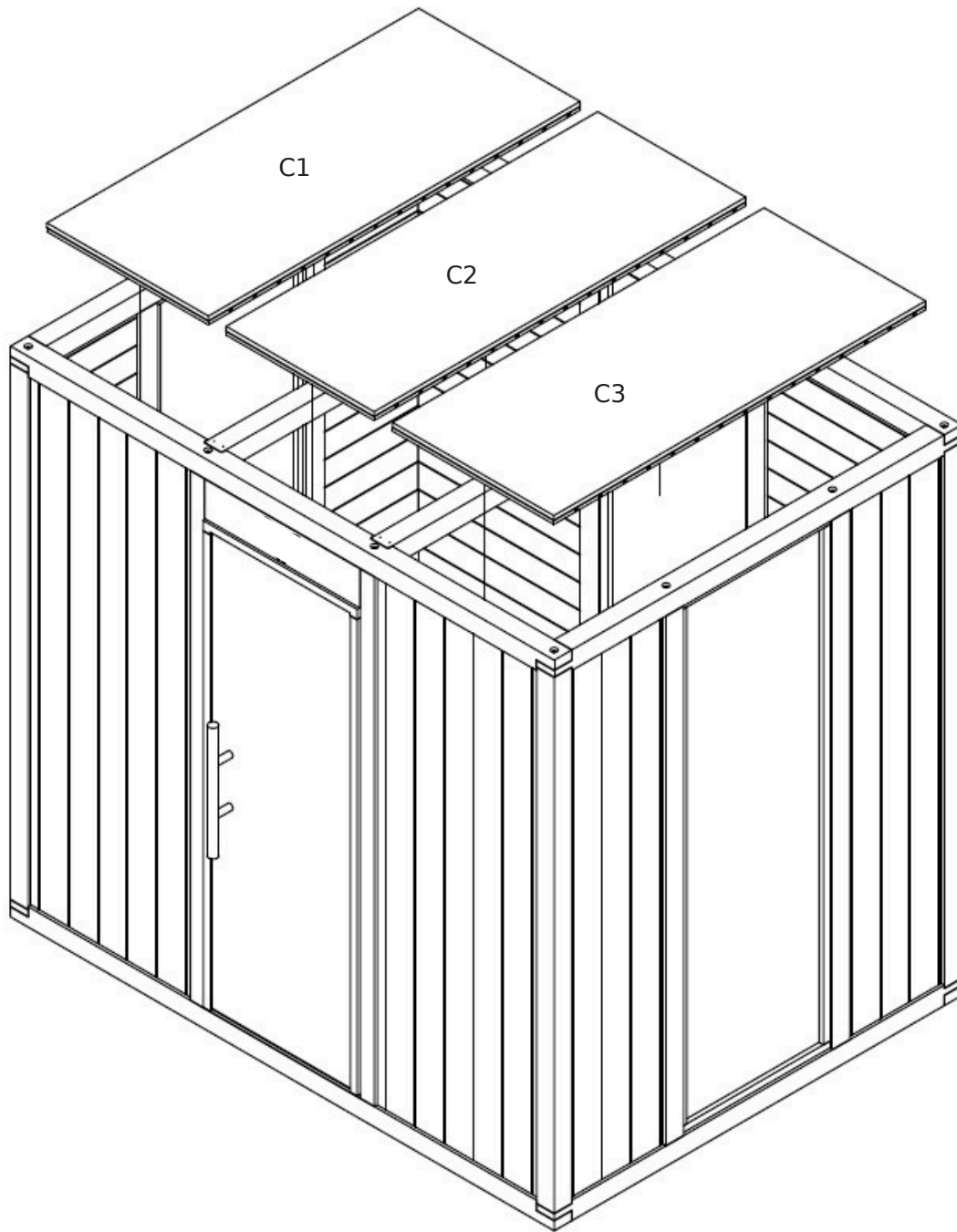

STEP 16

PLACE **RS1** AND LINE IT UP ON THE SHORT BEAM. THE ARROW WILL POINT TOWARDS THE "FRONT" OF THE ROOF. THE "FRONT" WILL BE THE TALLEST ROOF SIDE. START WITH A 4" SCREW INTO THE BACK, DON'T TIGHTEN COMPLETELY. MAKE SURE **RS1** IS STRAIGHT THEN USE THE 8" SCREW AND TIGHTEN DOWN. CONTINUE PUTTING THE SCREWS IN WITH THE 6", THEN 5", AND THEN TIGHTENING THE 4".

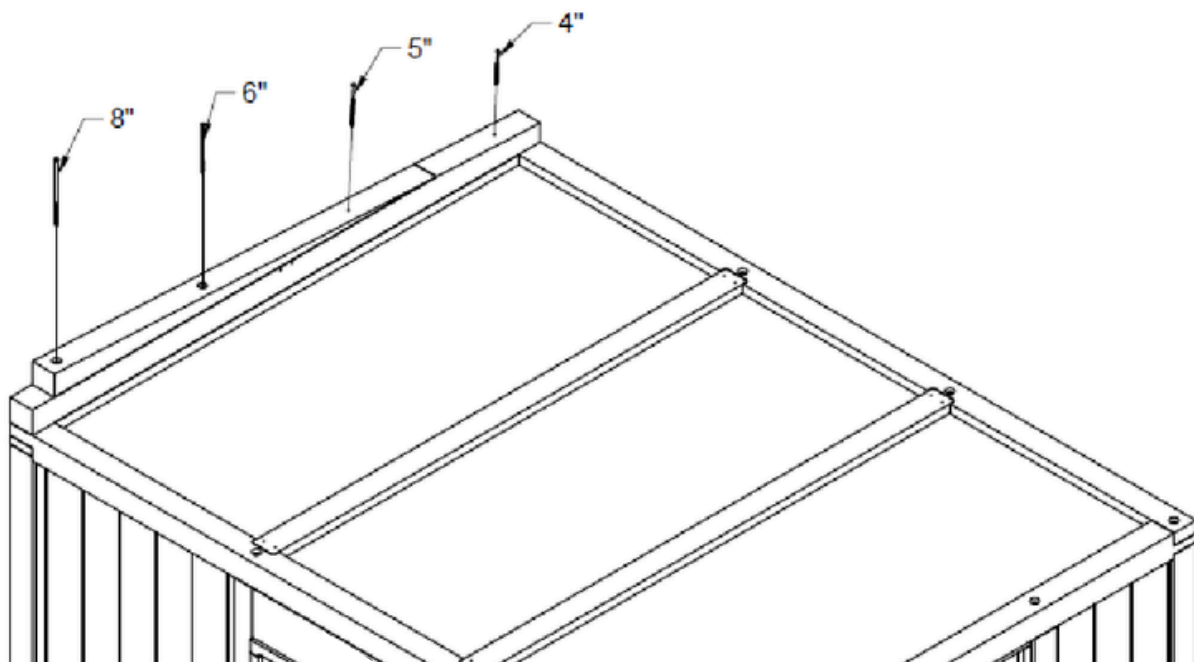
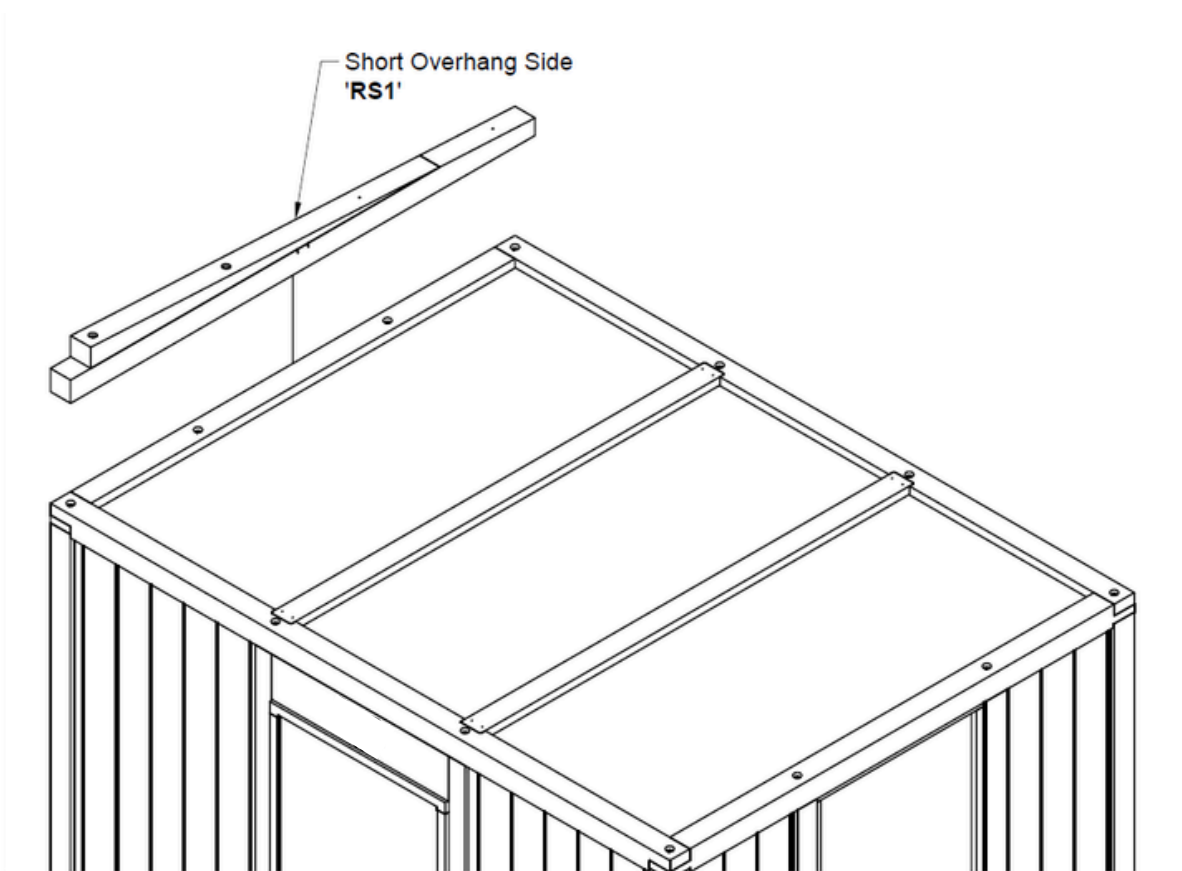

STEP 17

REPEAT STEP 16 WITH SIDE RS2.

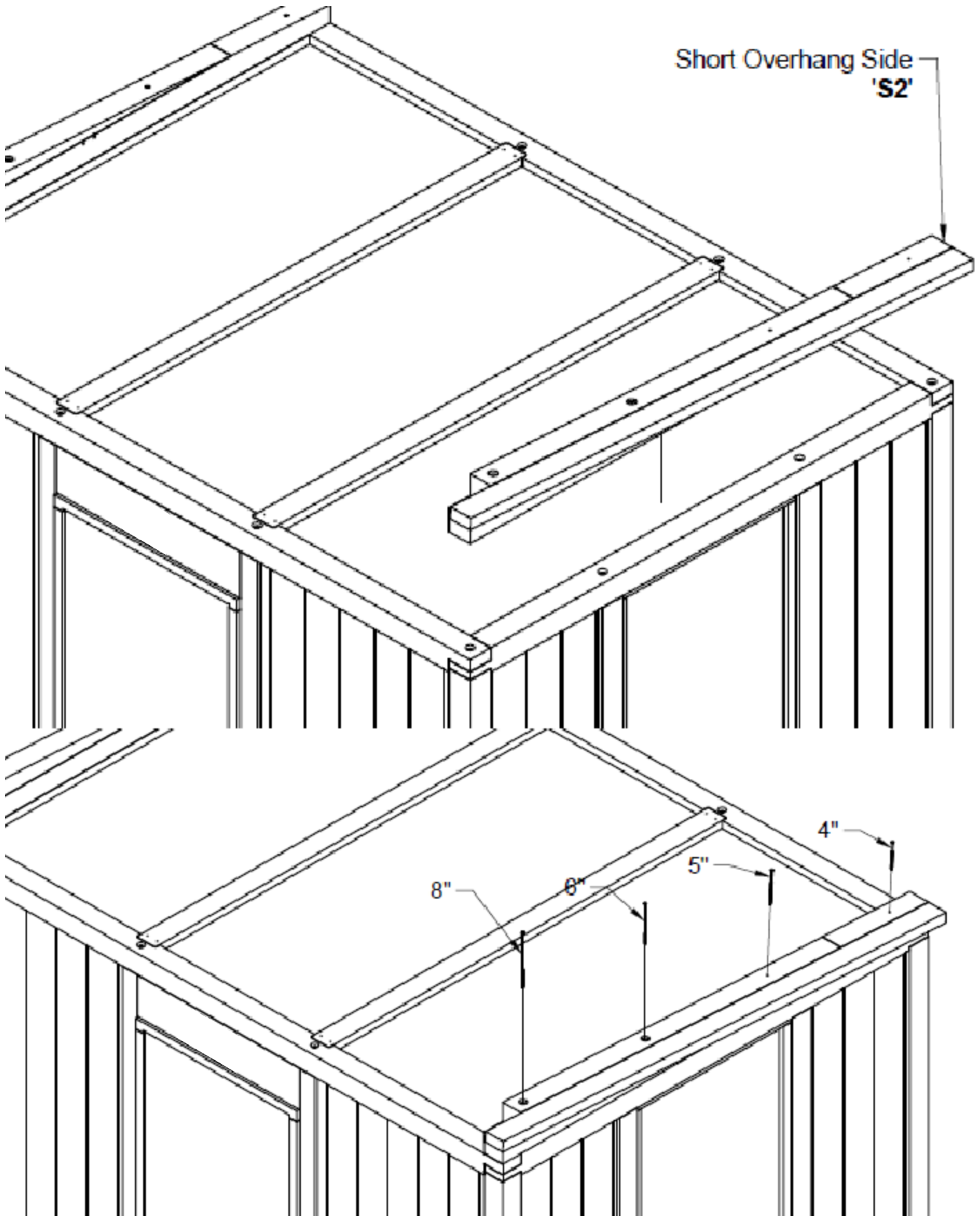

STEP 18

PLACE THE FRONT BEAM LABELED **FB** ONTO THE TOP FRONT SAUNA BEAM LABELED **FB** AS WELL. THE OVERHANG WILL BE FACING OUTWARD. STARTING FROM THE EDGES SCREW IN THE 8" SCREWS AND WORK TOWARDS THE CENTER.

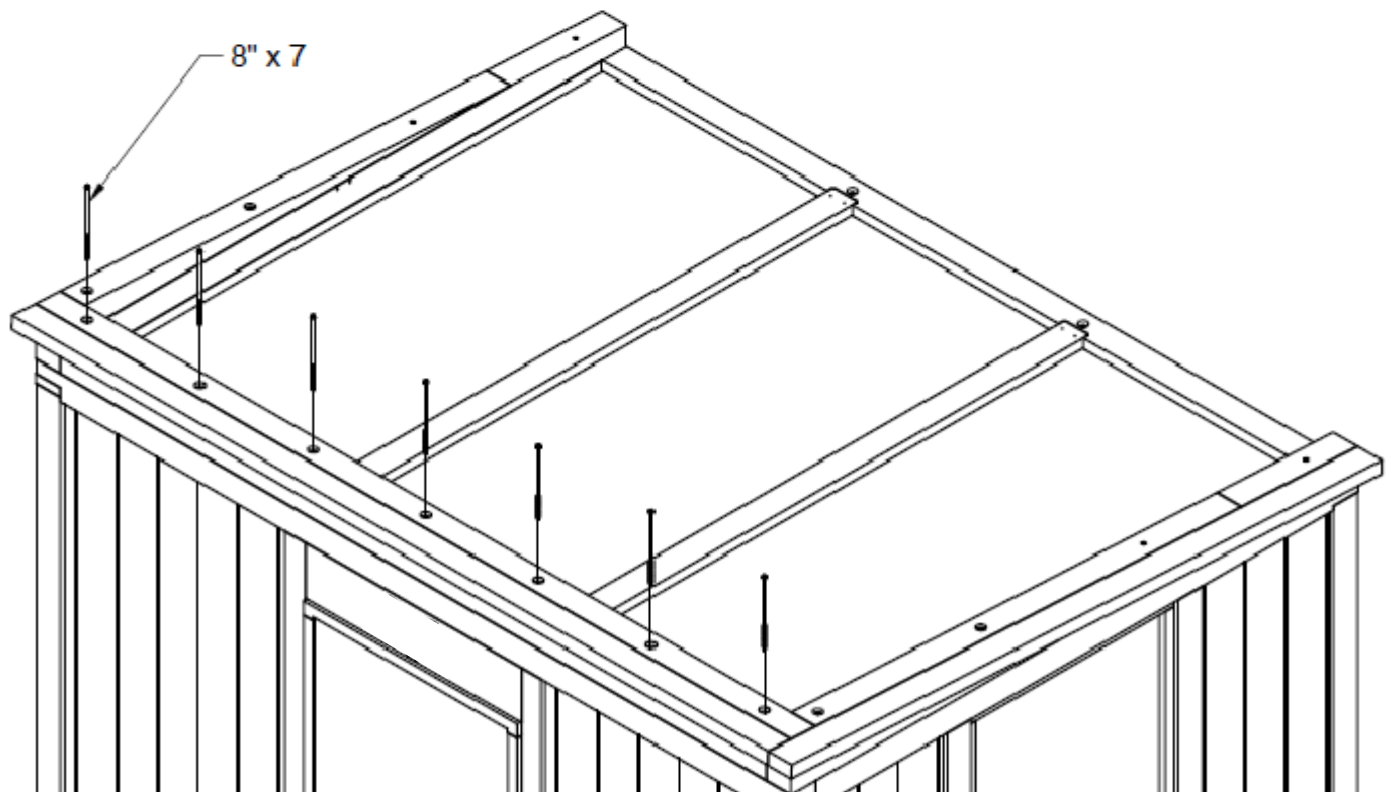
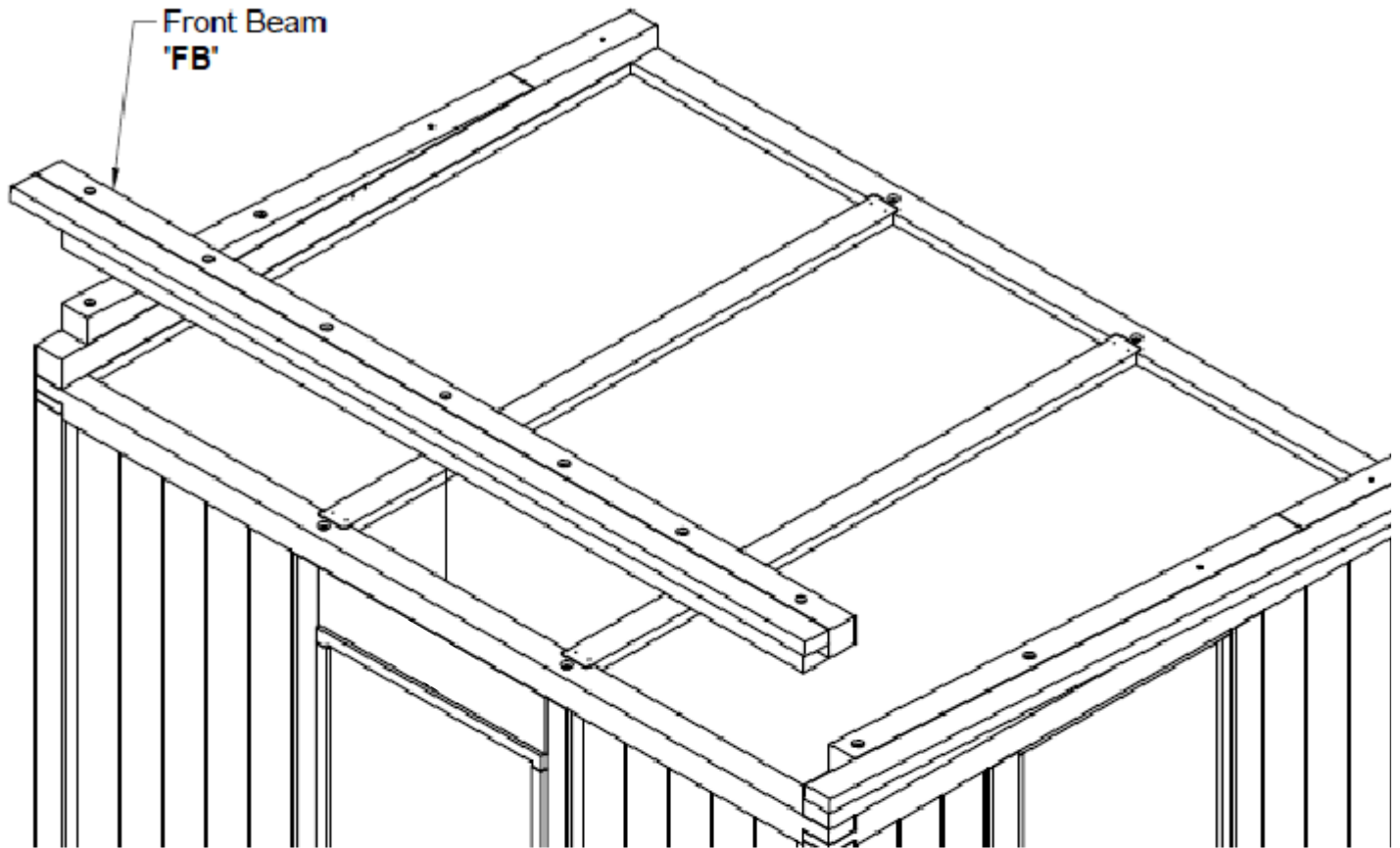

STEP 19

PLACE THE BACK BEAM LABELED **BB** ONTO THE TOP BACK SAUNA BEAM WITH THE ARROW POINTING TOWARDS THE FRONT OF THE SAUNA. STARTING FROM THE EDGES SCEW IN THE 3" SCREWS WORKING TOWARDS THE CENTER.

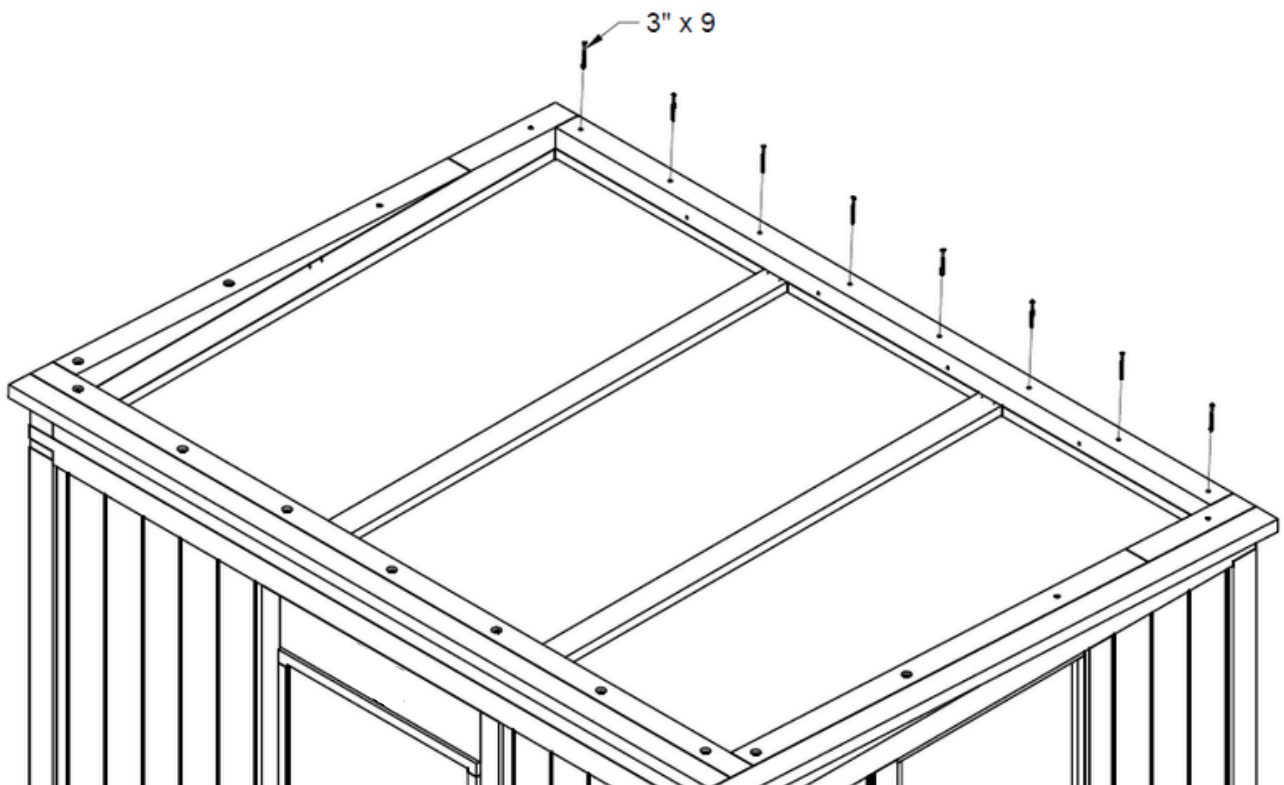
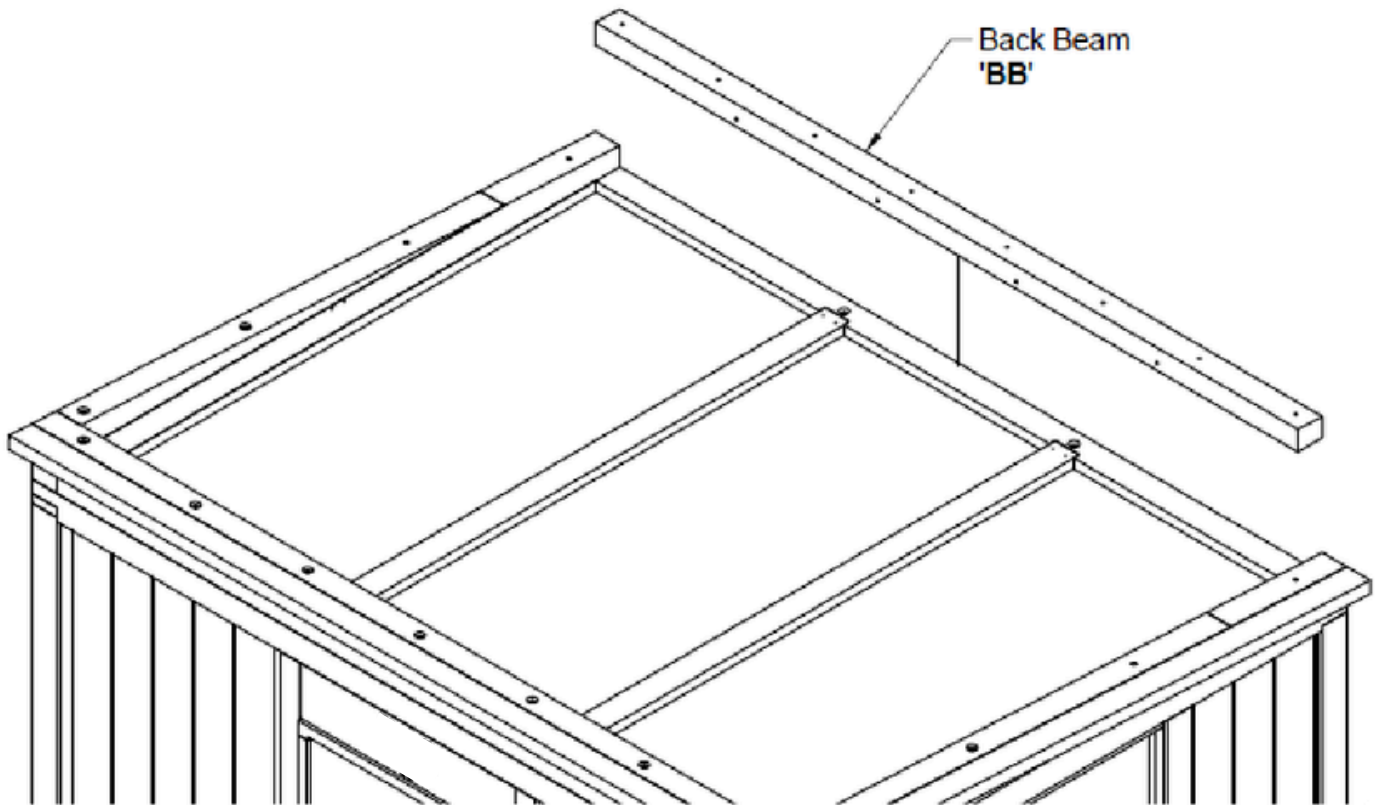

STEP 20

LINE UP THE NUMBERED BACK BRACES WITH THE CORRESPONDING NUMBERS ON THE BACK BEAM. FASTEN THE BRACES TO THE BACK BEAM WITH TWO 3" SCREWS.

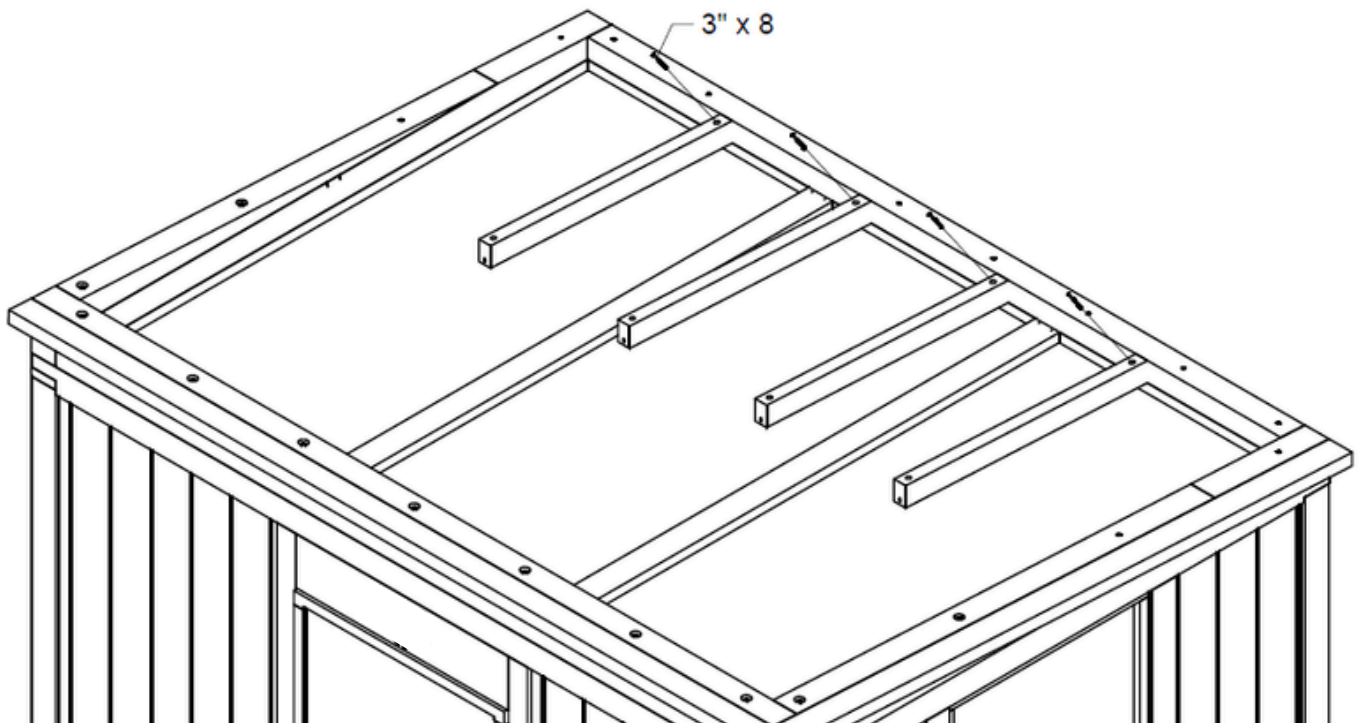
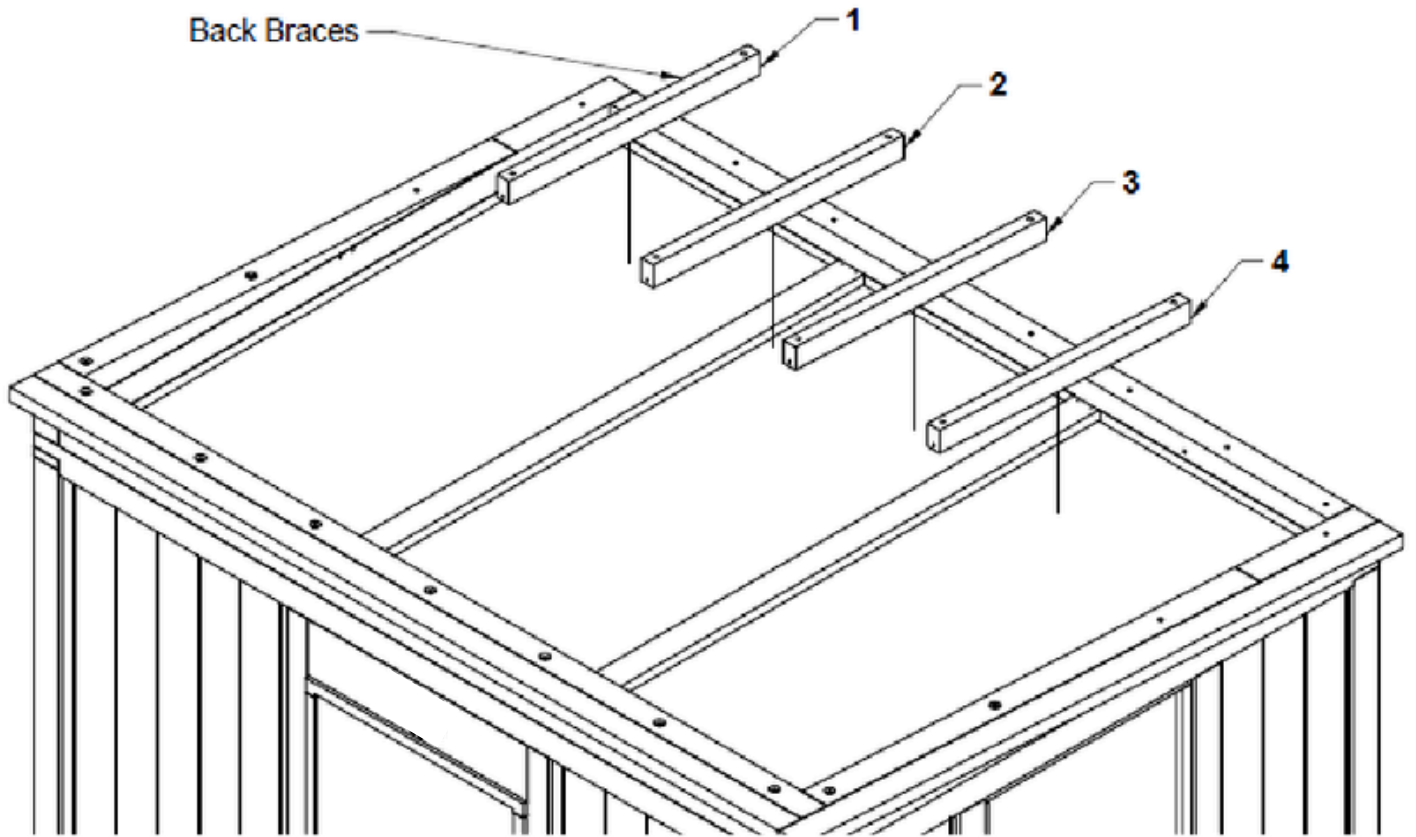

STEP 21

PLACE THE CROSS BEAM LABELED **CB** WITH THE ARROW FACING THE FRONT UP AGAINST THE BACK BRACES THEN TIGHTEN IT INTO THE SIDE BEAMS WITH TWO 4" SCREWS ON EACH SIDE.

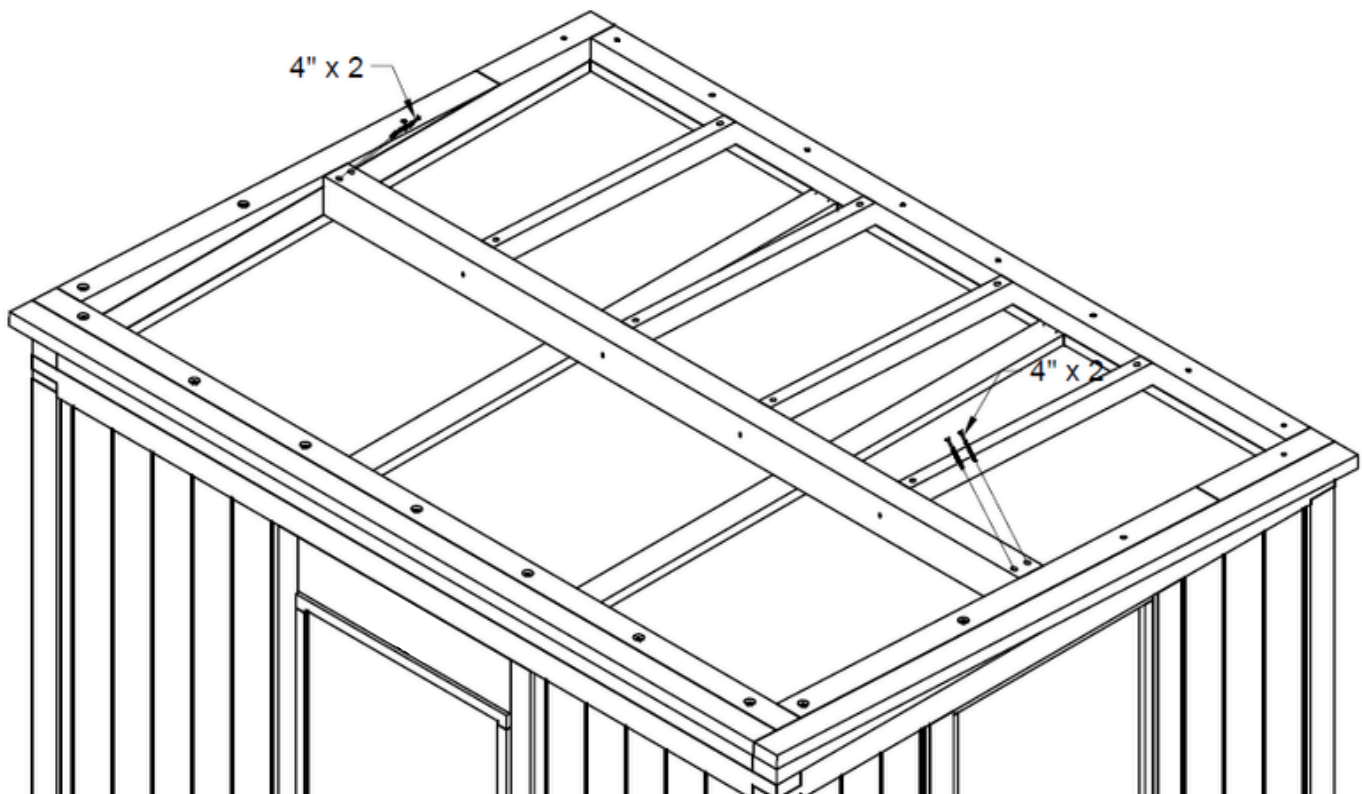
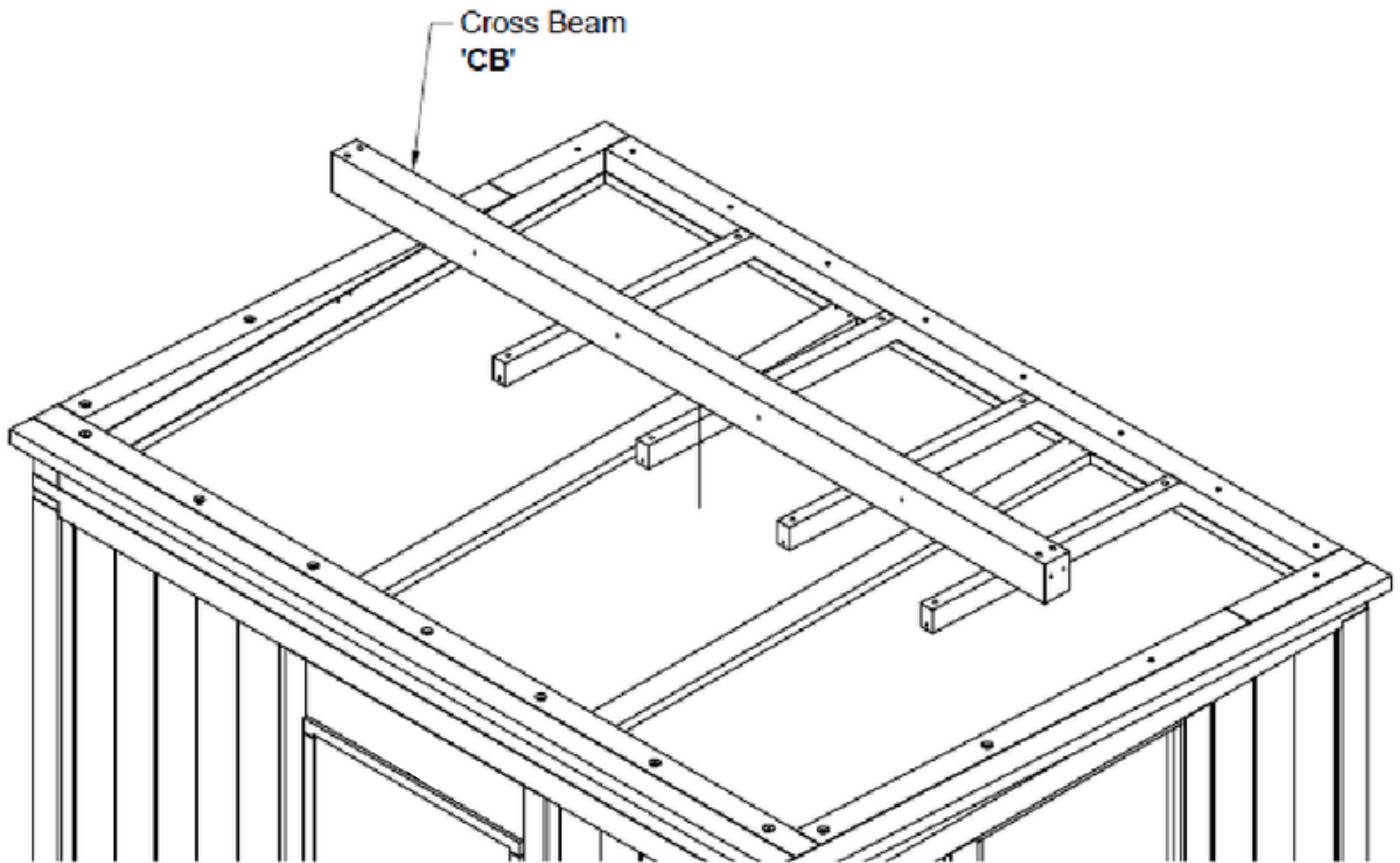

STEP 22

SCREW THE 3" SCREWS INTO THE CROSS BEAM FROM BACK BRACES.

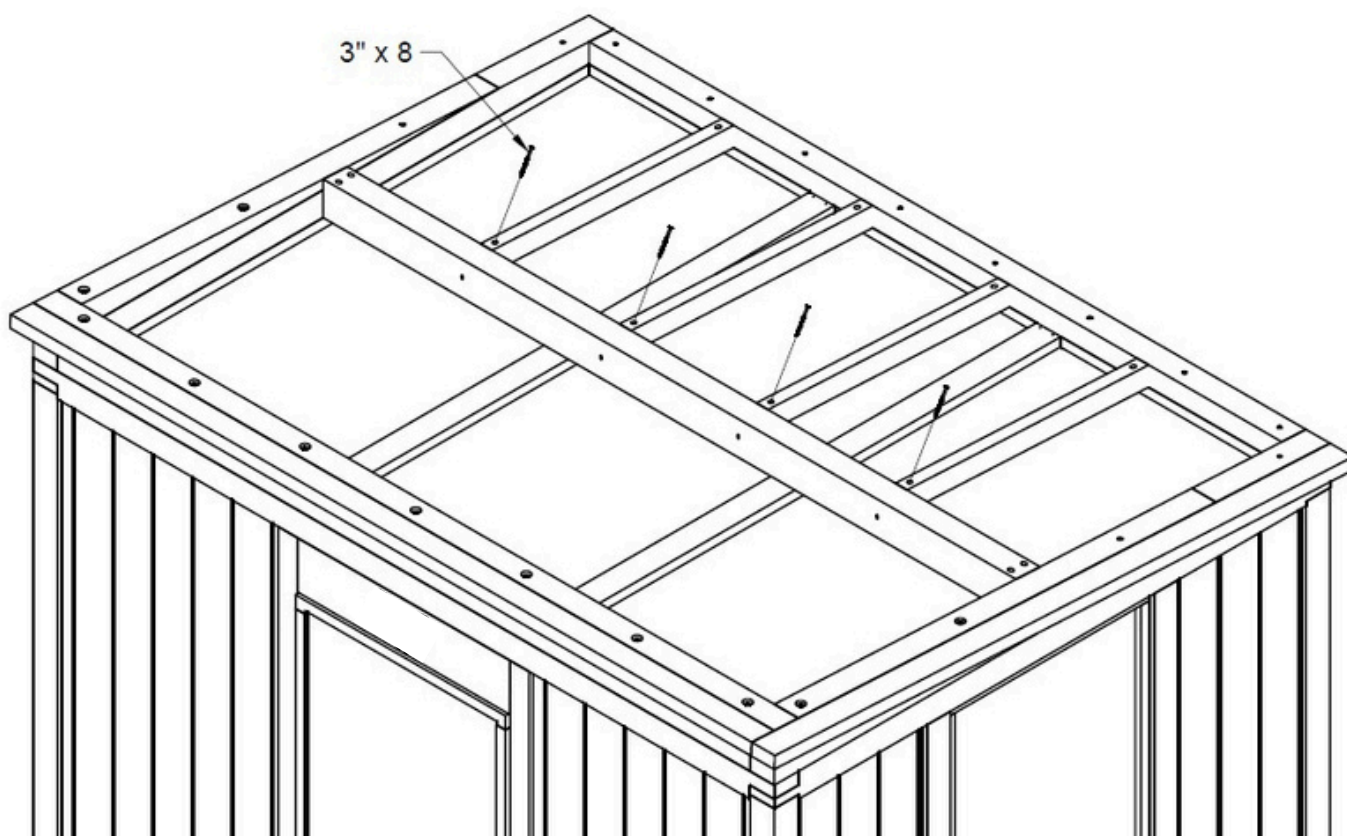

STEP 23

LINE UP THE NUMBERED FRONT BRACES INTO POSITION WITH THE NUMBERS LISTED ON THE FRONT BEAM AND SCREW THEM INTO BOTH THE FRONT BEAM AND CROSS BEAM WITH 3" SCREWS. A MALLET MAY BE REQUIRED TO GET THE BRACES INTO POSITION.

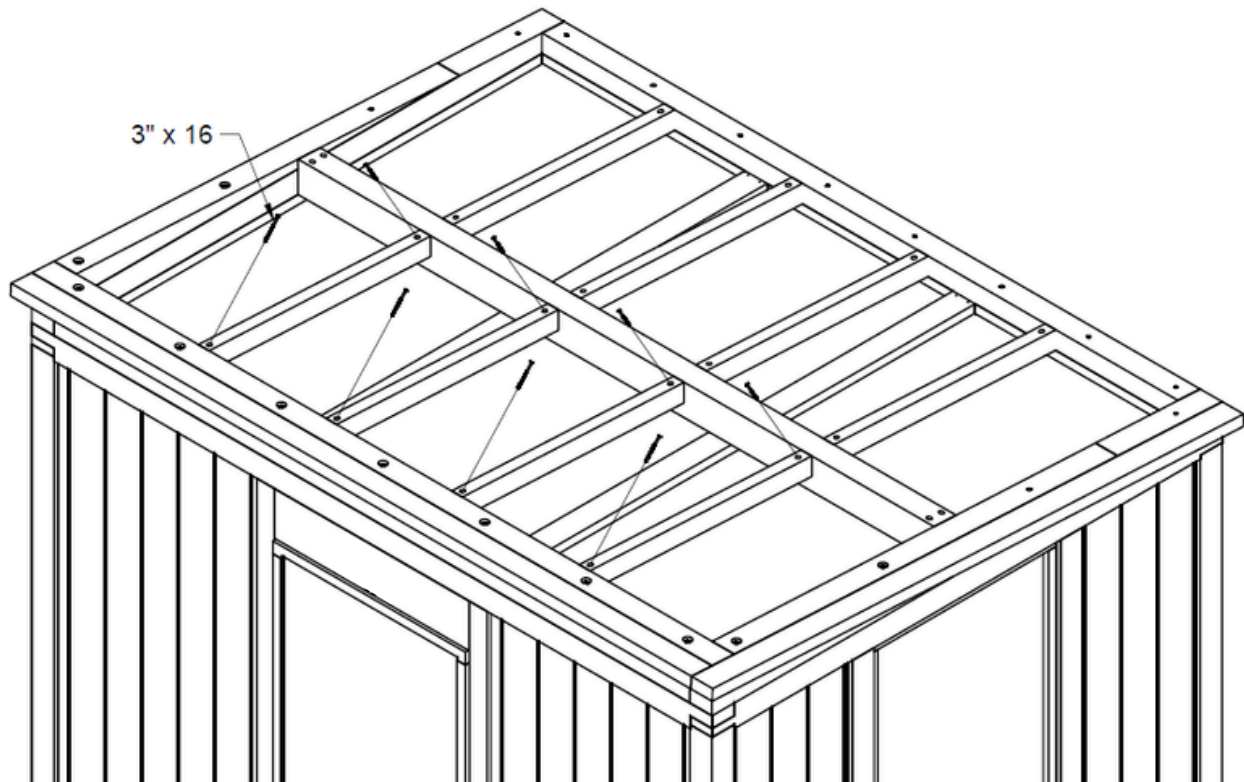
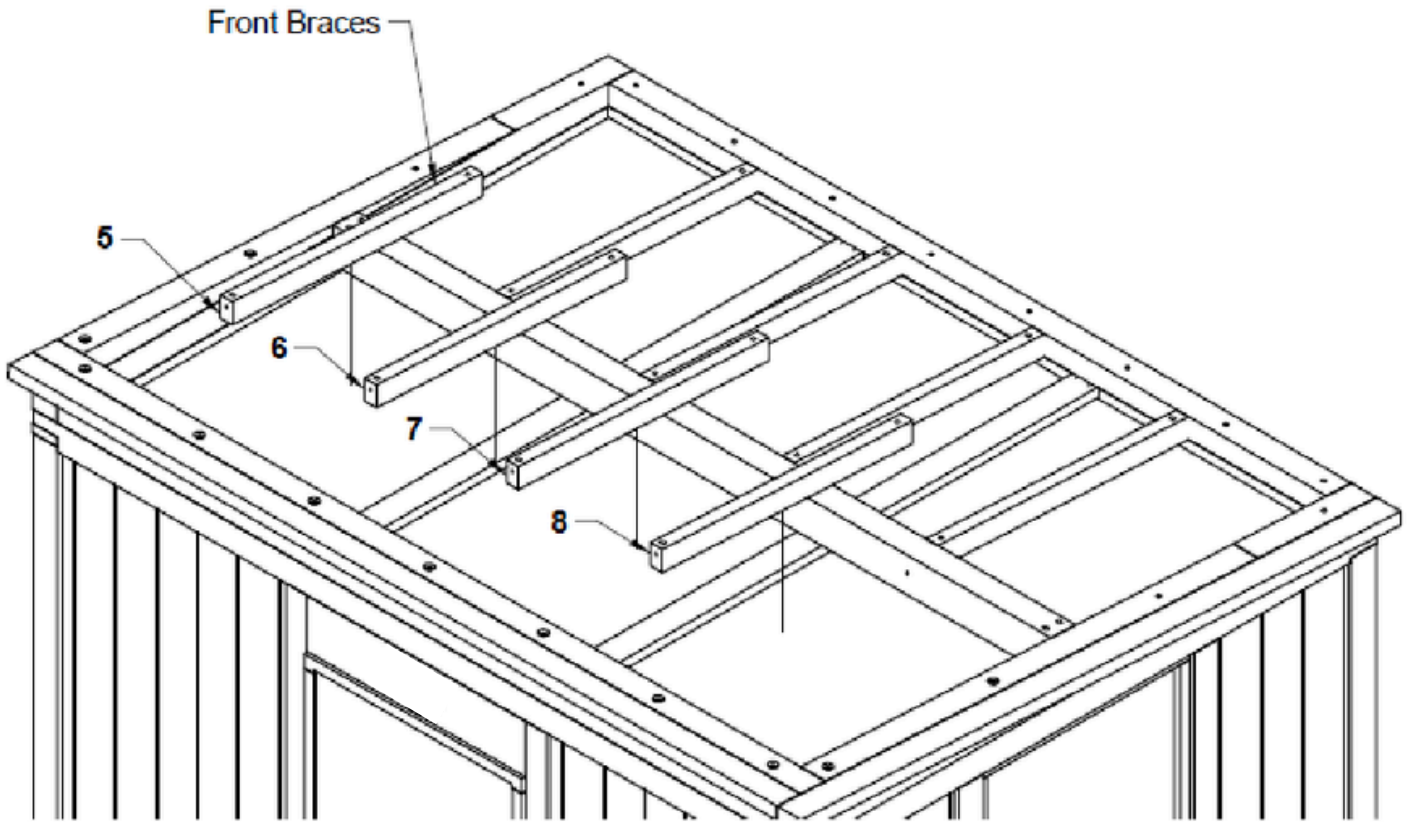

STEP 24

ATTACH THE SMALL PIECE OF PLYWOOD LABELED **RSP** ALONG THE OUTER EDGE OF THE RIGHT OVERHANG ON THE SHORT SIDE ROOF BEAM WITH 17 - 1 1/4" SCREWS

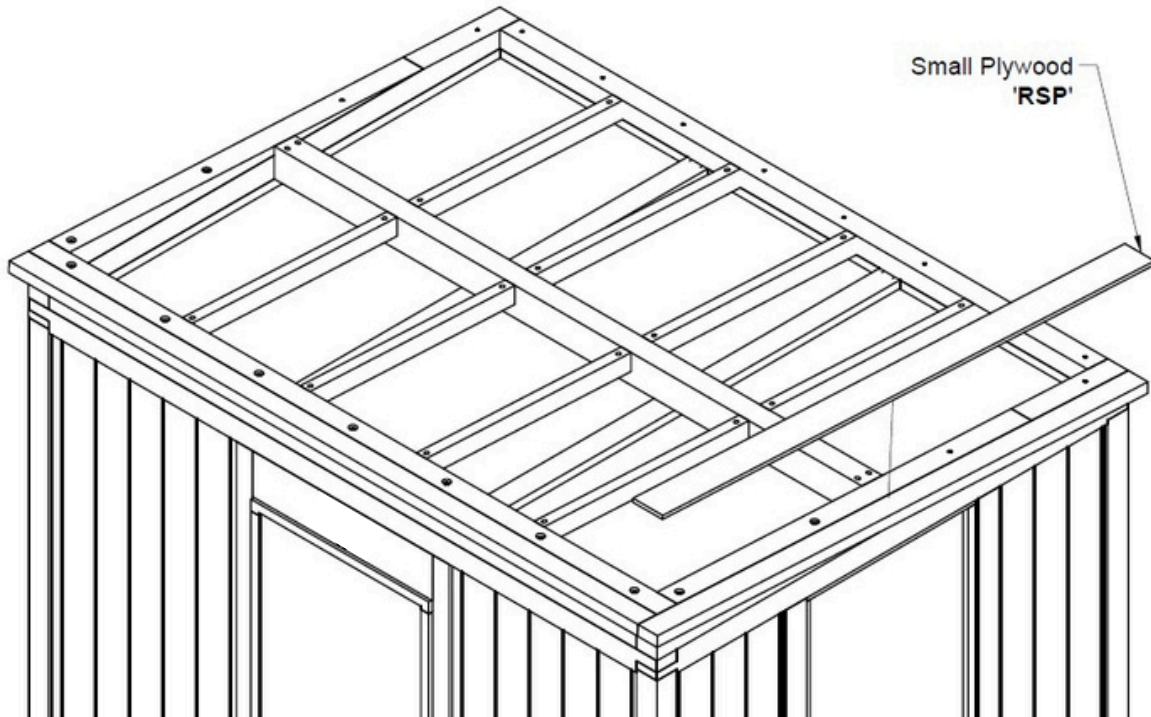

STEP 25

ATTACH THE PLYWOOD LABELED **RP1** AND **RP2** WITH 25 - 1 1/4" SCREWS

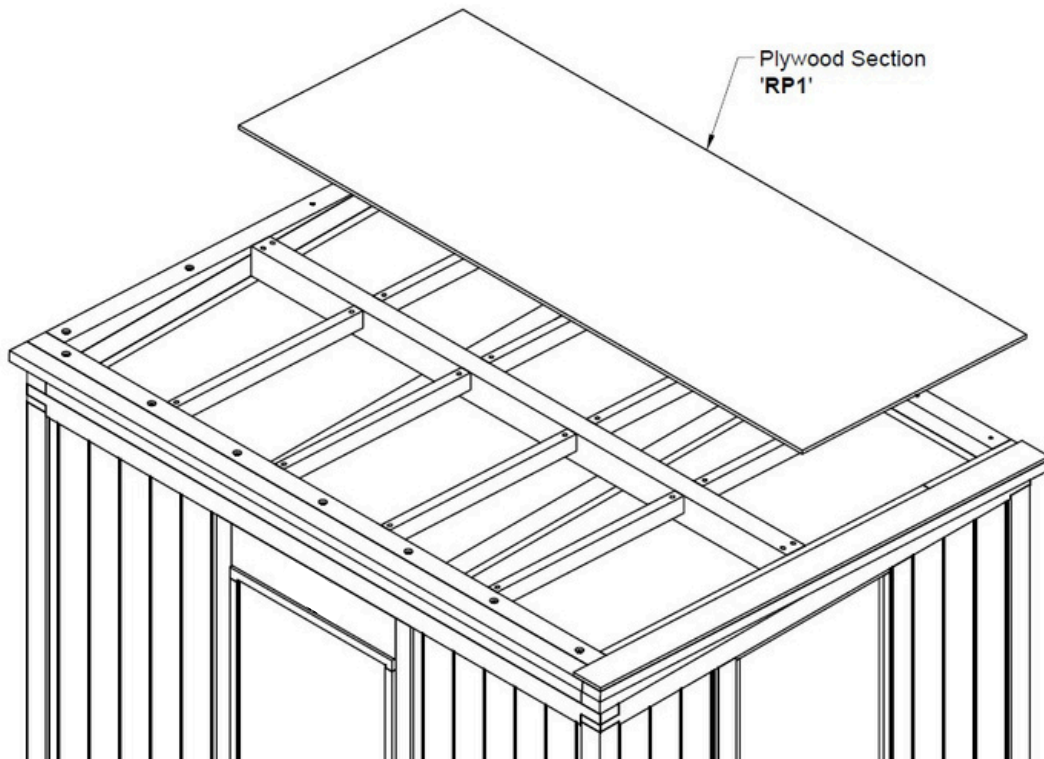

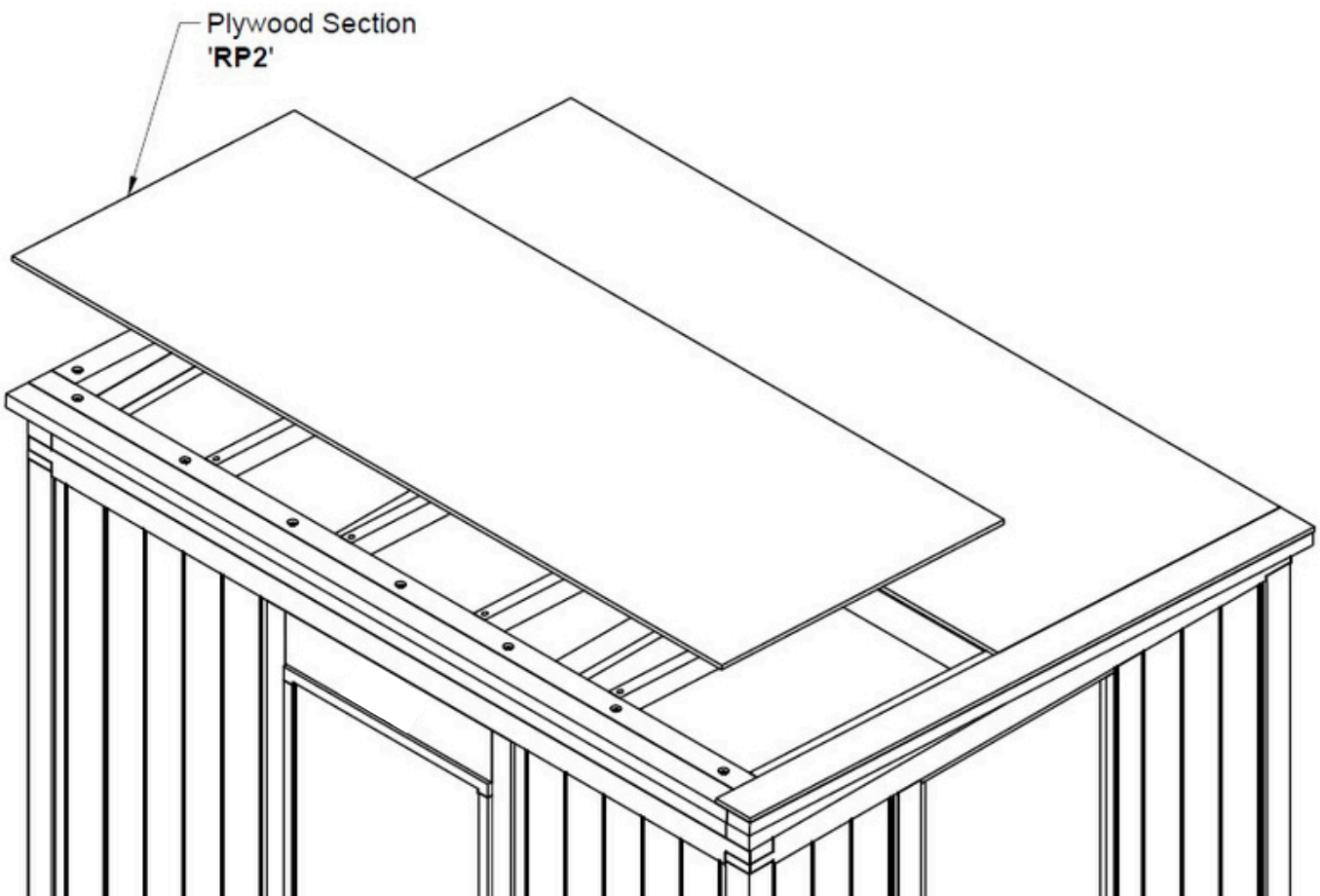

STEP 26

LAYDOWN THE UNDERLAYMENT ONTO THE PLYWOOD AND STAPLE IT DOWN WITH A STAPLE GUN AND CUTTING THE EXCESS OFF.

STEP 27

ATTACH THE BACK DRIP EDGE ONTO UNDERLAYMENT. ALL OF THE METAL ROOFING MATERIALS ARE ATTACHED USING 1" ROOFING SCREWS WITH A 1/4' SOCKET

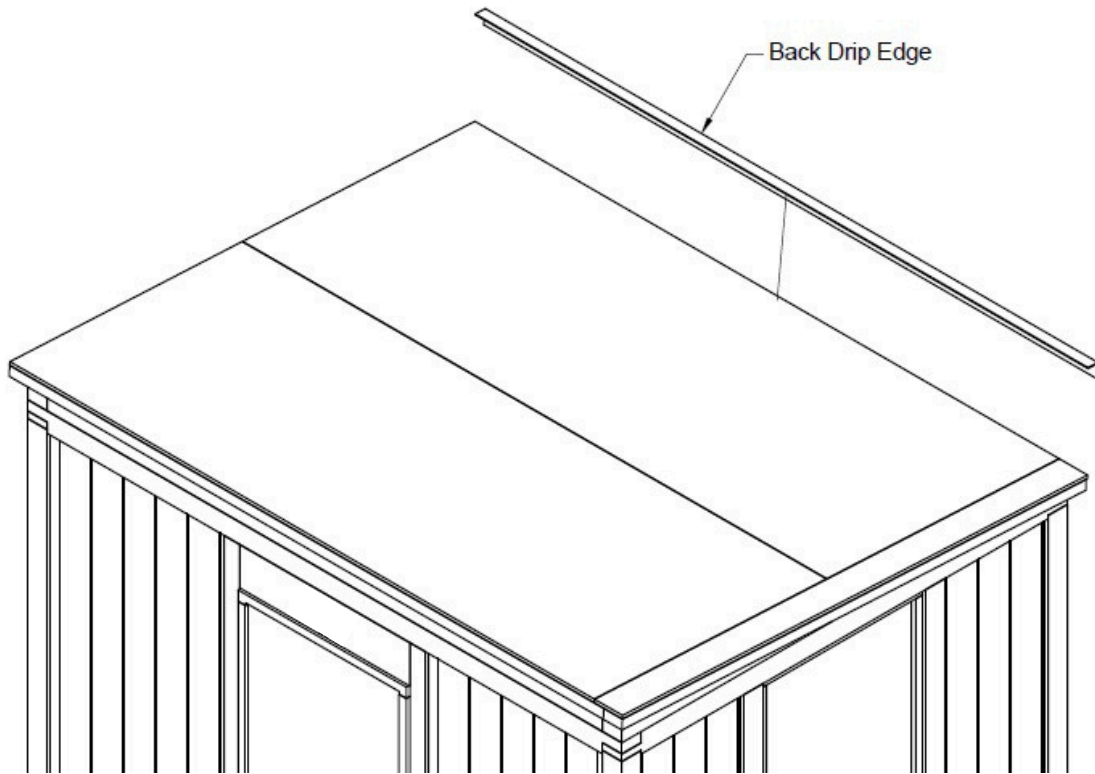

STEP 28

ATTACH THE TIN ROOF SECTION LABELED **T1** WITH THE ARROW POINTING TO THE FRONT ON THE FRONT EDGE ONLY.

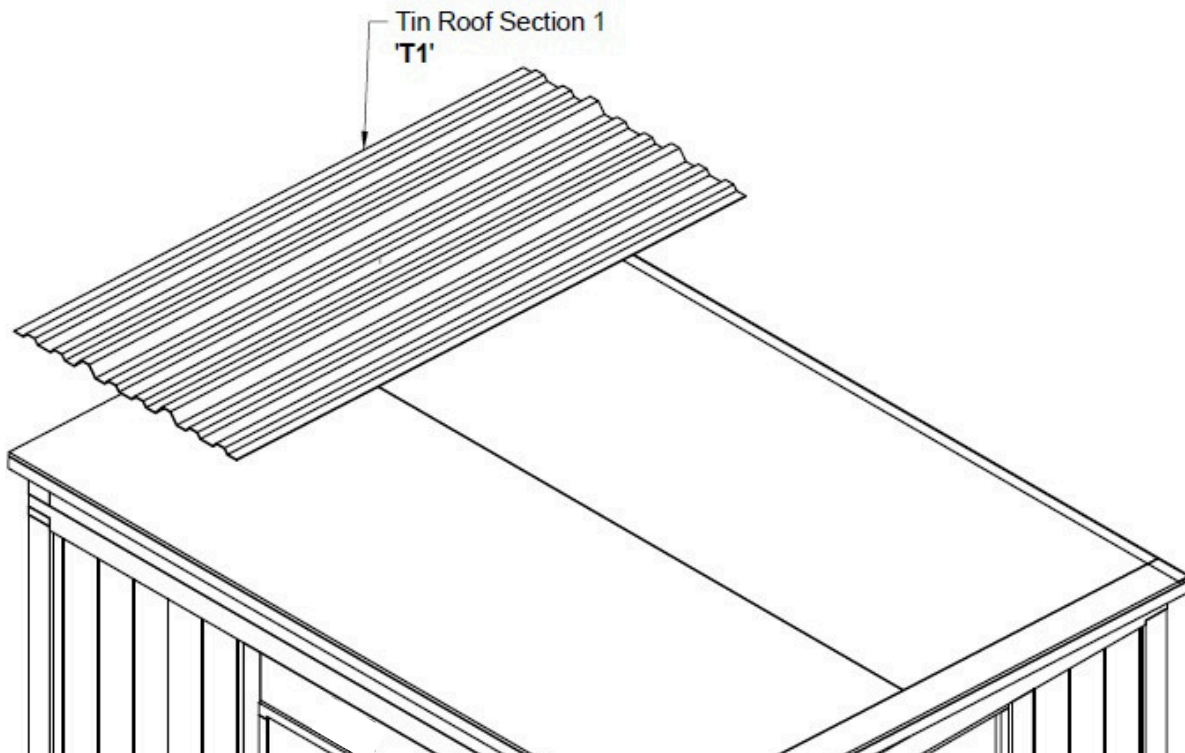

STEP 29

SLIDE THE FIRST SECTION OF DRIP EDGE FOAM UNDER **T1** ALIGNING THE RIDGES OF THE FOAM WITH THE TIN. CONNECT THE OTHER FOAM SECTIONS. CUT ANY EXCESS FOAM OFF. FINISH ATTACHING **T1** TO THE ROOF.

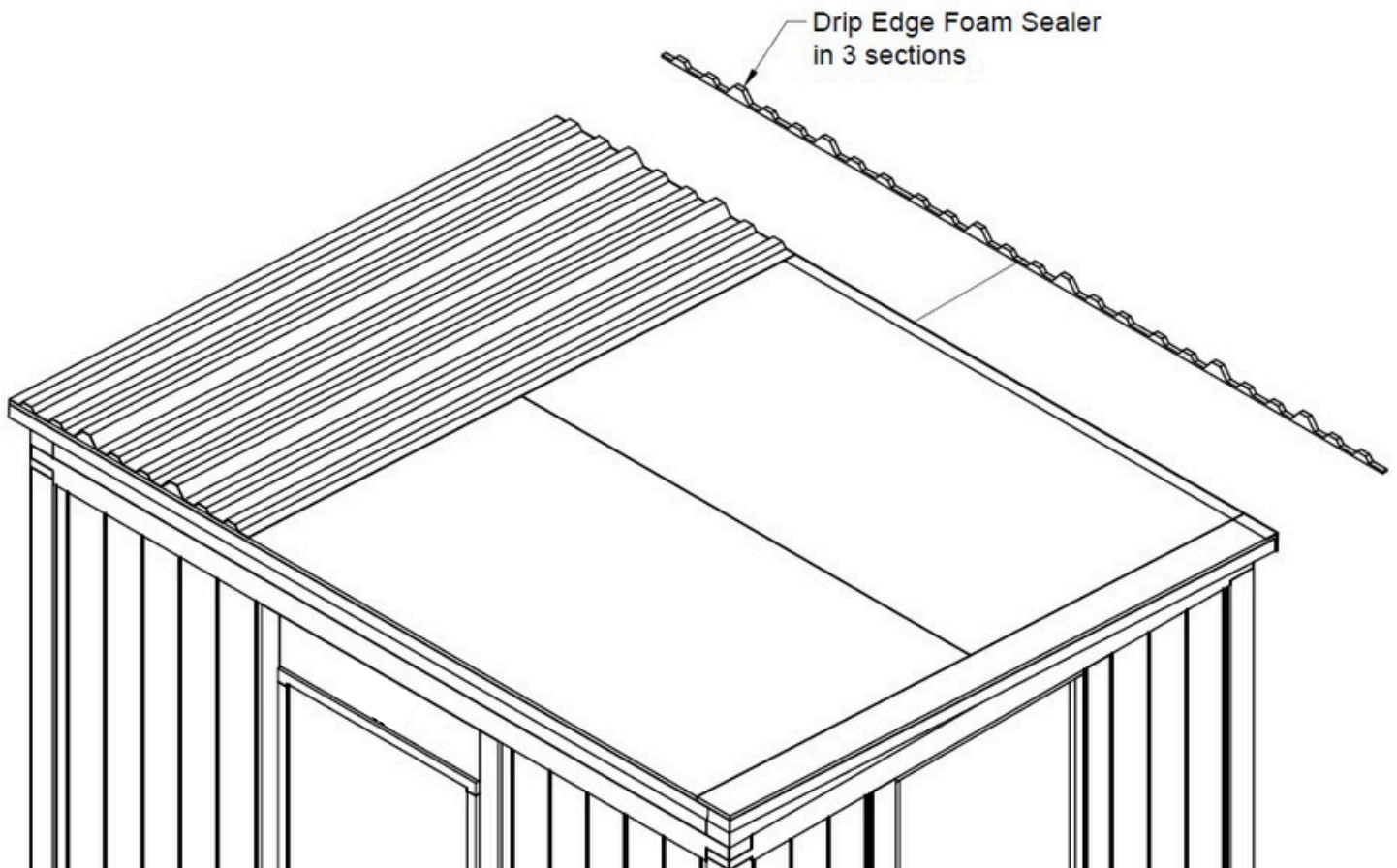

STEP 30

ATTACH **T2** AND **T3** TIN ROOF SECTIONS TO THE ROOF.

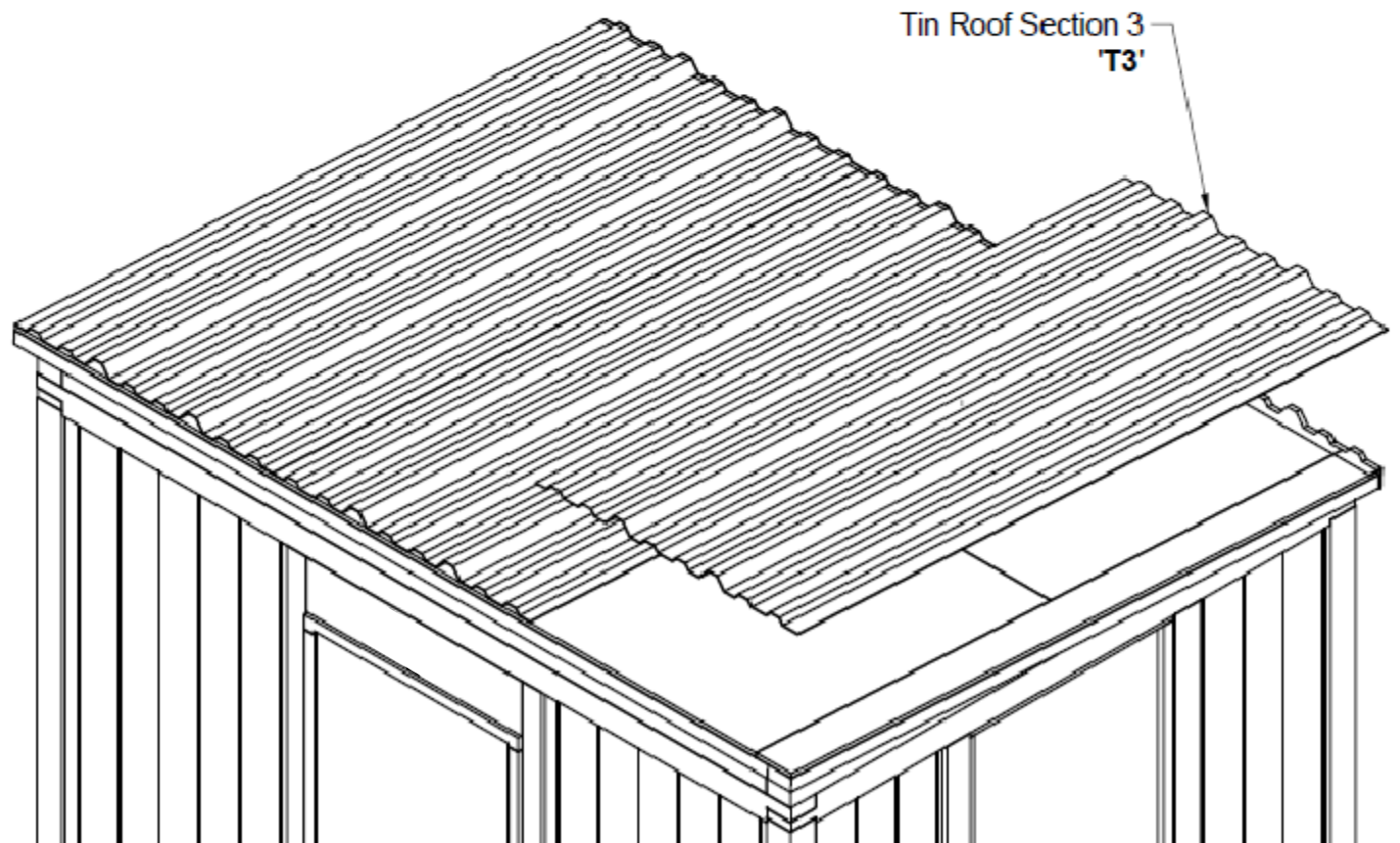
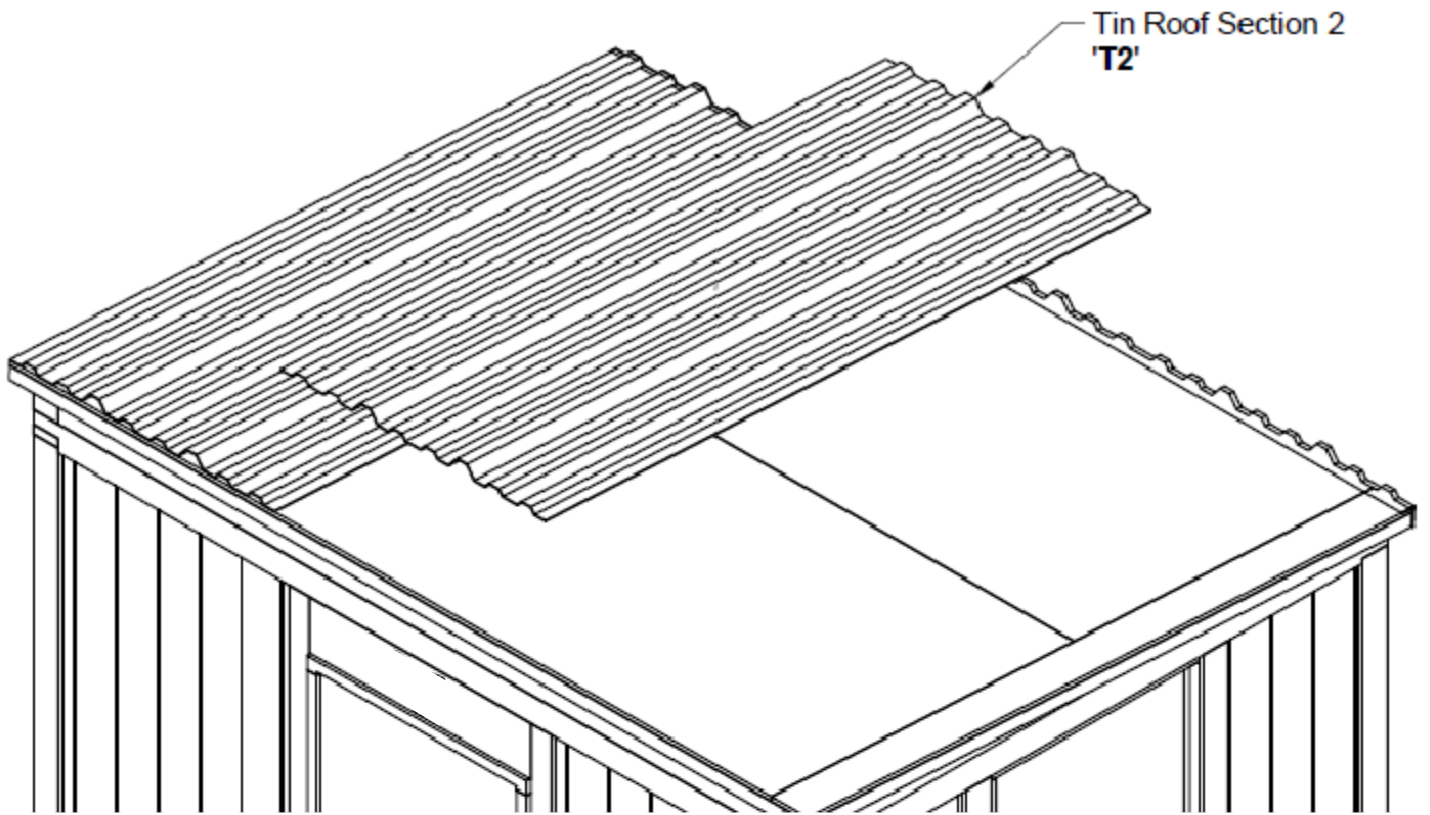

STEP 31

ATTACH THE 2SIDE CAPS LABELED **SC** ON EITHER SIDE OF THE ROOF. AN ARROW WILL POINT TOWARDS THE FRONT OF THE SAUNA.

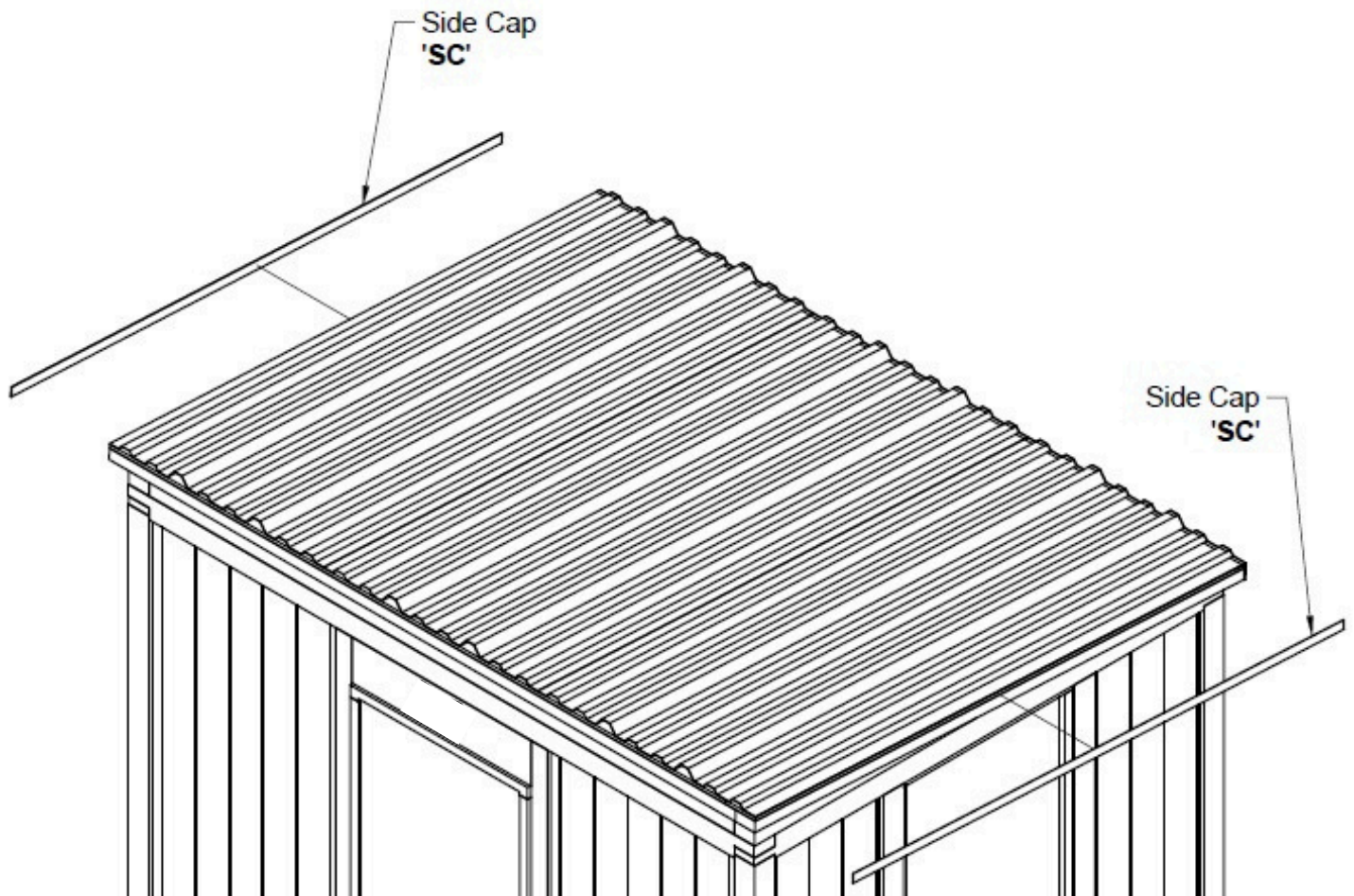

STEP 32

ALIGN ONE SECTION THE FRONT EDGE FOAM TO THE RIDGES OF THE ROOF, STARTING FROM ONE SIDE AND CONNECTING THE OTHER SECTIONS. CUT OFF ANY EXCESS. ATTACH THE FRONT EDGE CAP.

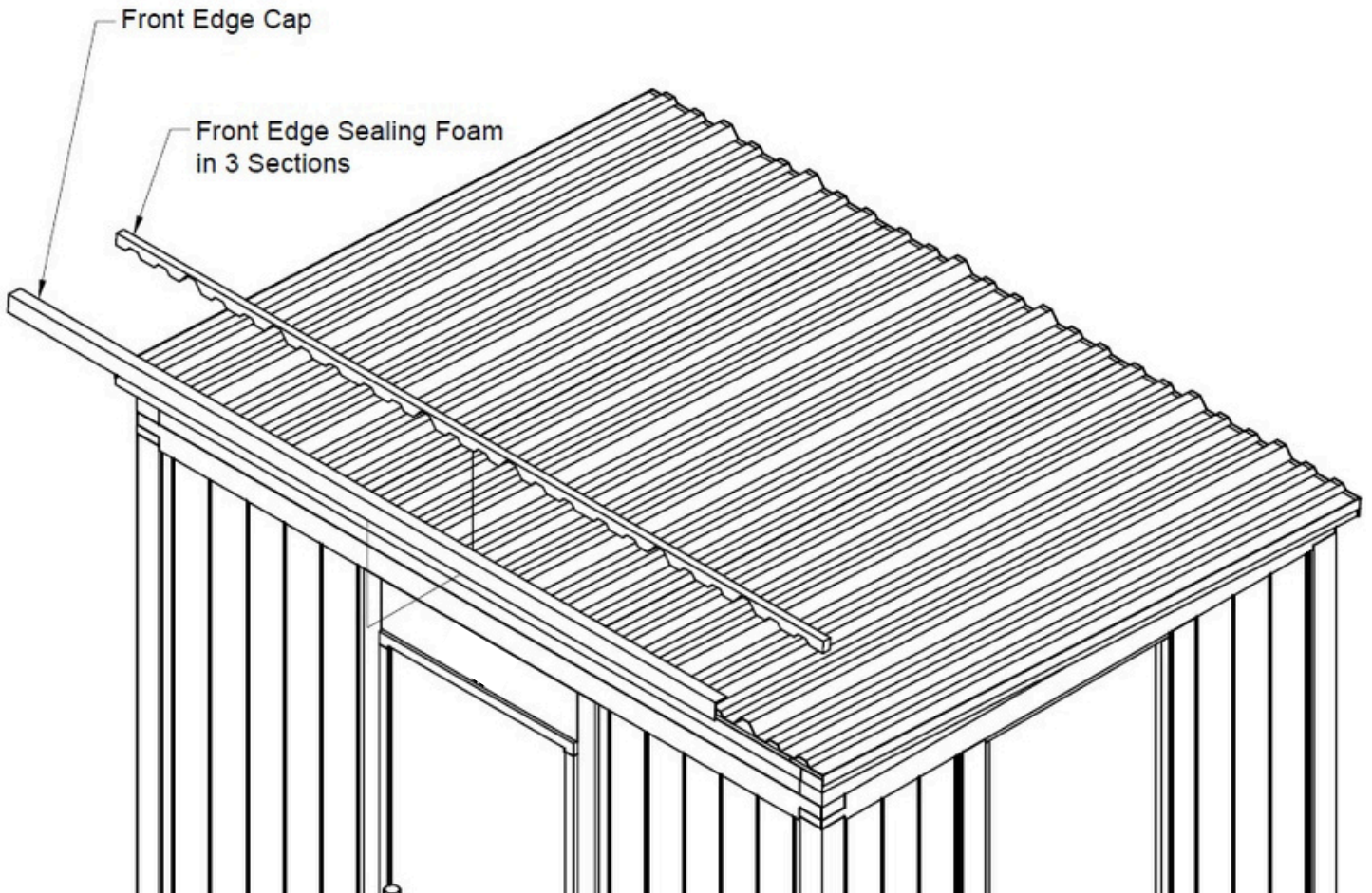

STEP 33

THE ROOF SHOULD NOW BE COMPLETED.

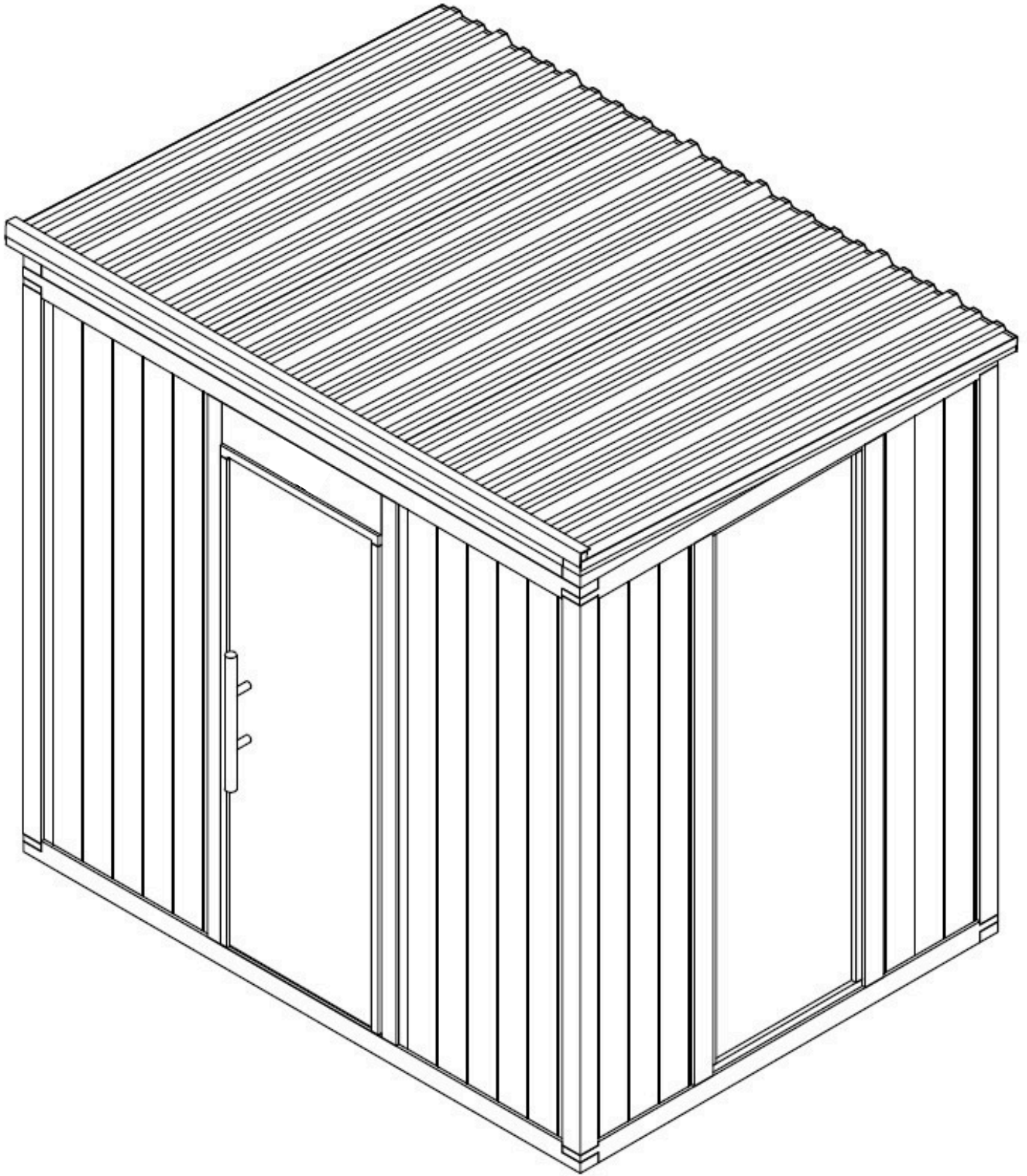

STEP 34

THE FOUR BENCH SUPPORTS WILL NEED TO HAVE THEIR CROSS SUPPORTS ATTACHED. THE BENCH SUPPORTS HAVE HOLES PRE-DRILLED AND ARE NUMBERED TO MATCH A CORRESPONDING NUMBERED CROSS SUPPORT. THERE ARE TWO LEFT AND TWO RIGHT BENCH SUPPORTS.

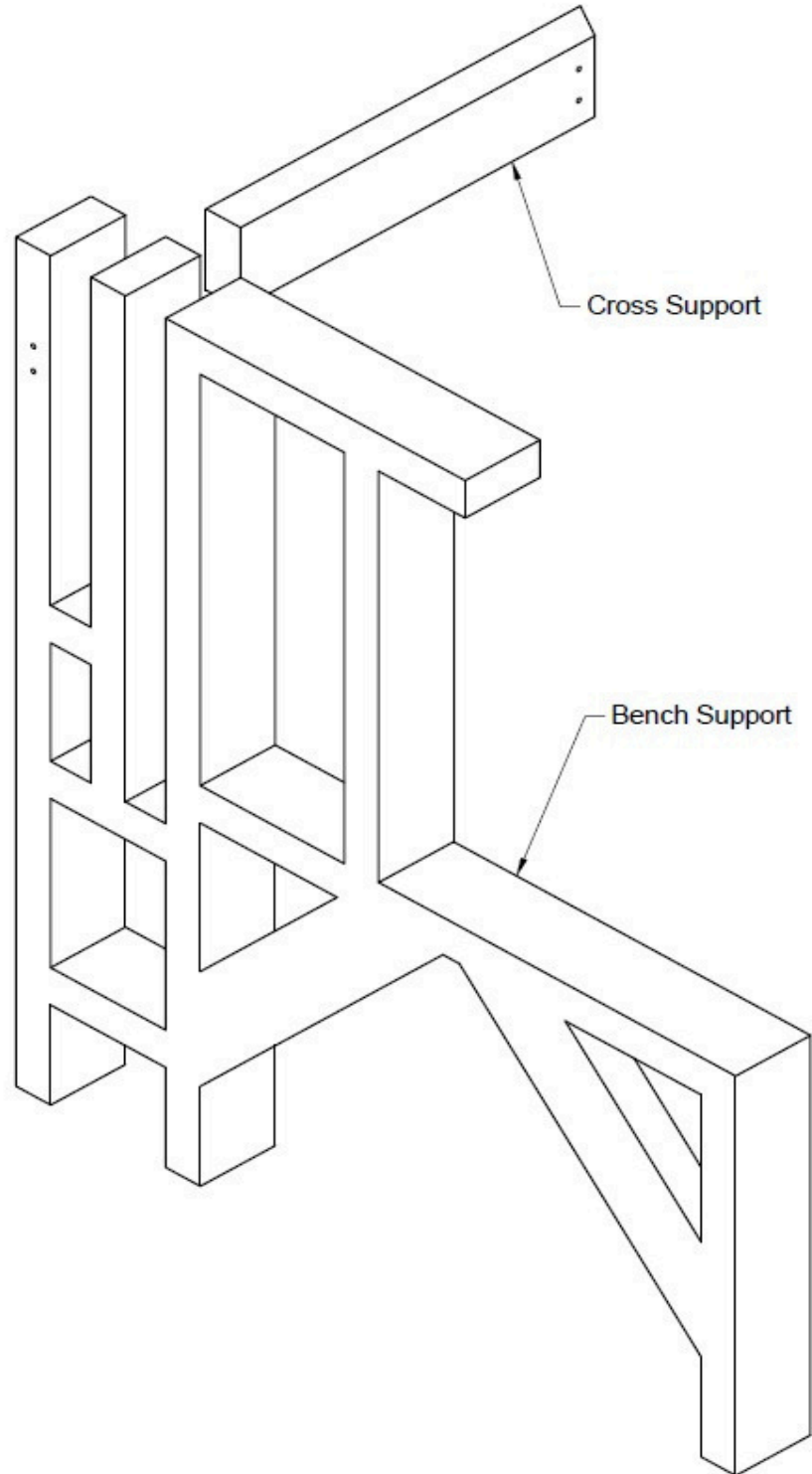

STEP 35

SCREW THE TWO 5" SCREWS THROUGH THE BENCH SUPPORT INTO THE CROSS SUPPORT USING THE T25 TORX BIT. MAKE SURE THE CROSS SUPPORT HAS THE ANGLE FACING THE FRONT OF THE SUPPORT. DO THIS FOR EACH BENCH SUPPORT.

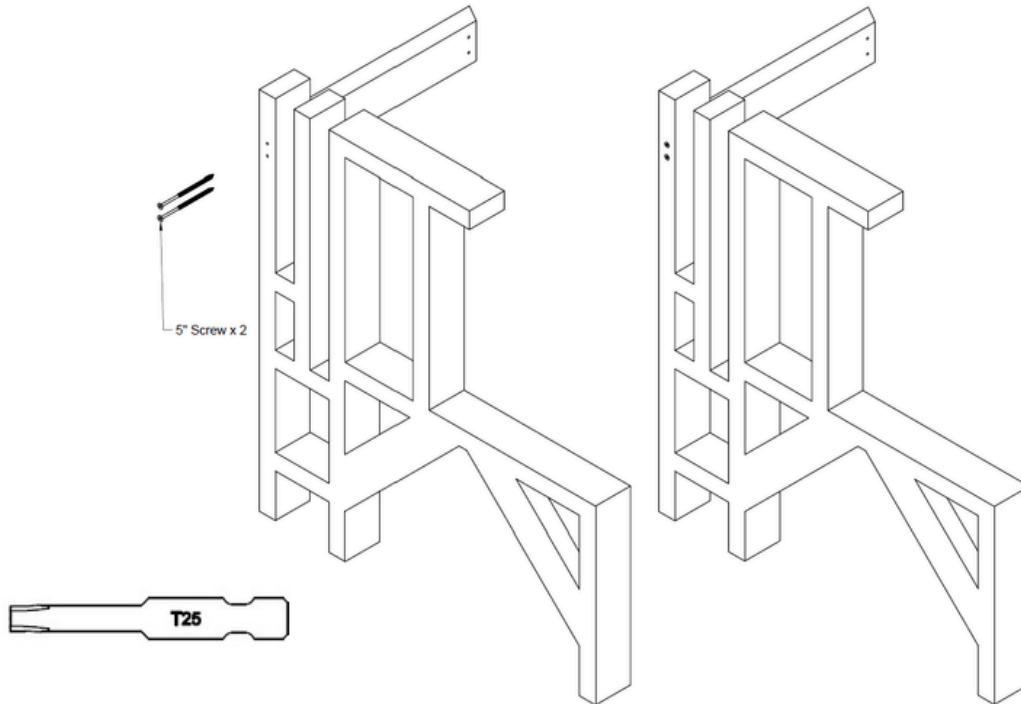

STEP 36

POSITION A LEFT AND A RIGHT BENCH SUPPORT INTO THE CORNERS ON THE LEFTSIDE OF THE SAUNA.

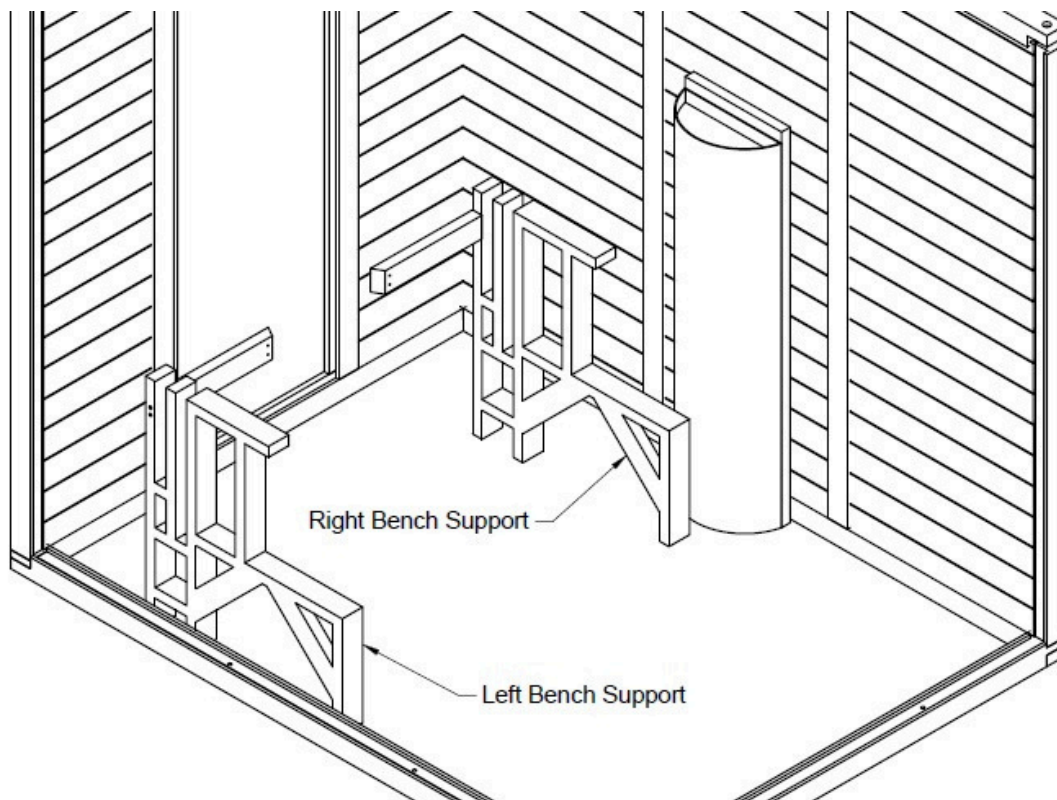

STEP 37

PLACE A BOTTOMBENCH ONTO THE SUPPORTS. USING A LEVEL, ADJUST THE LEVELING FEET ON THE SUPPORTS UNTIL THE BENCH IS LEVEL FROM LEFT TO RIGHT AND FRONT TO BACK.

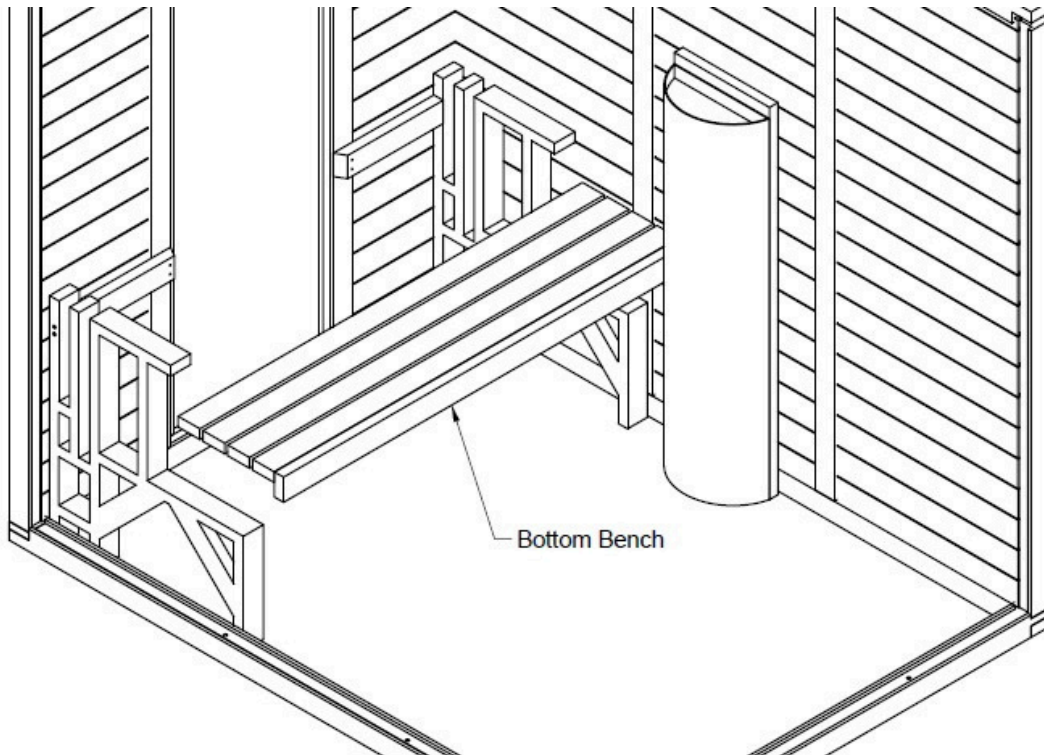

STEP 38

ONCE THE BENCH IS LEVELED, SCREW THE CROSS SUPPORTS INTO THE POSTS USING TWO 3" SCREWS ON EACH SIDE USING THE T25 TORX BIT.

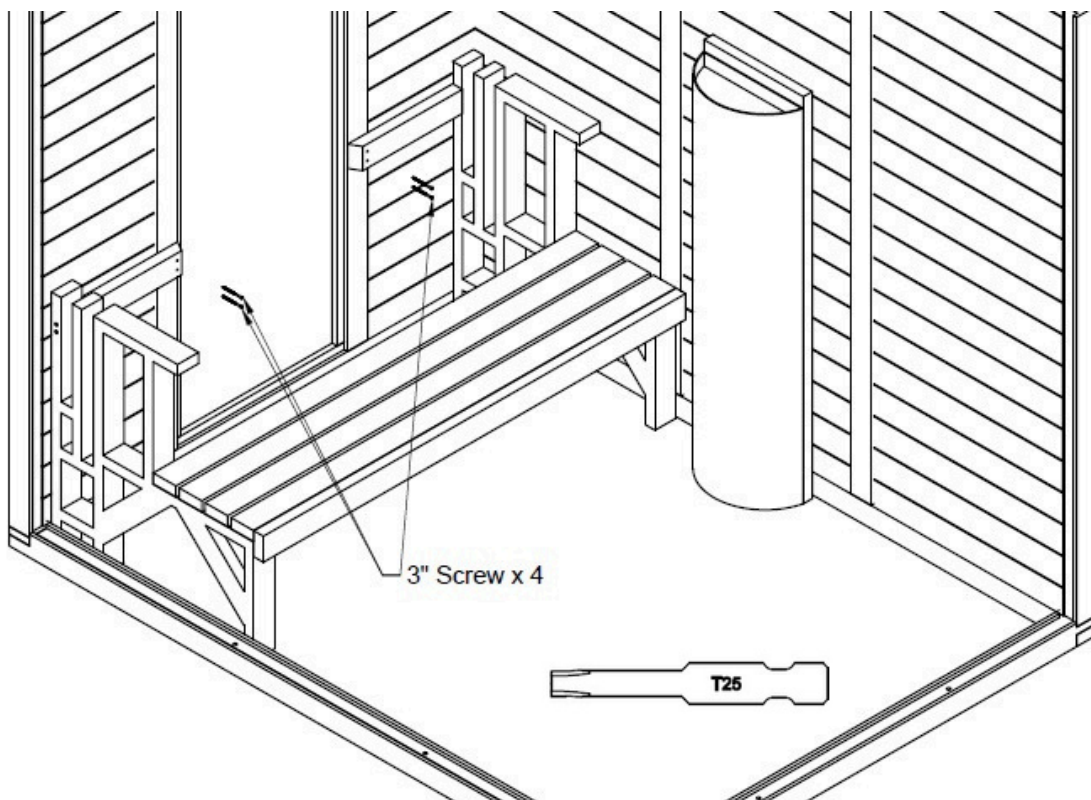

STEP 39

SLIDE TOP BENCH INTO POSITION.

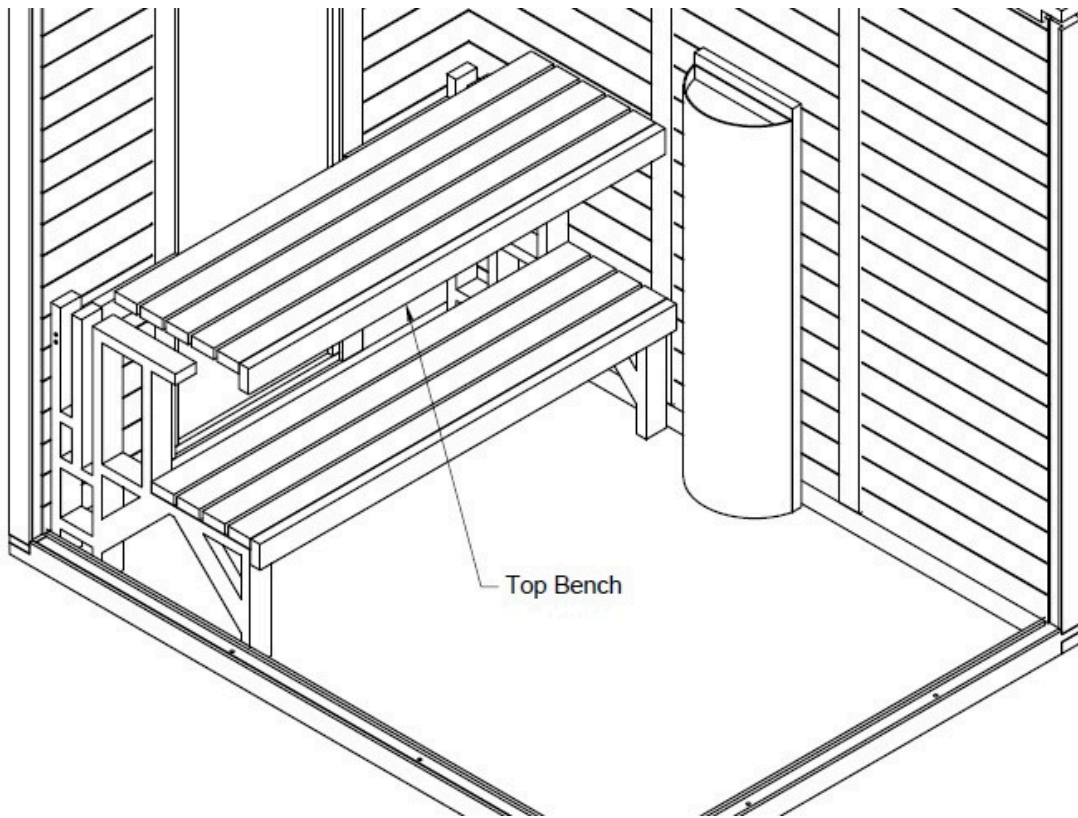

STEP 40

REPEAT THE PROCESS WITH THE RIGHT BENCHES. POSITION A LEFT AND A RIGHT BENCH SUPPORT INTO THE CORNERS ON THE RIGHT SIDE OF THE SAUNA.

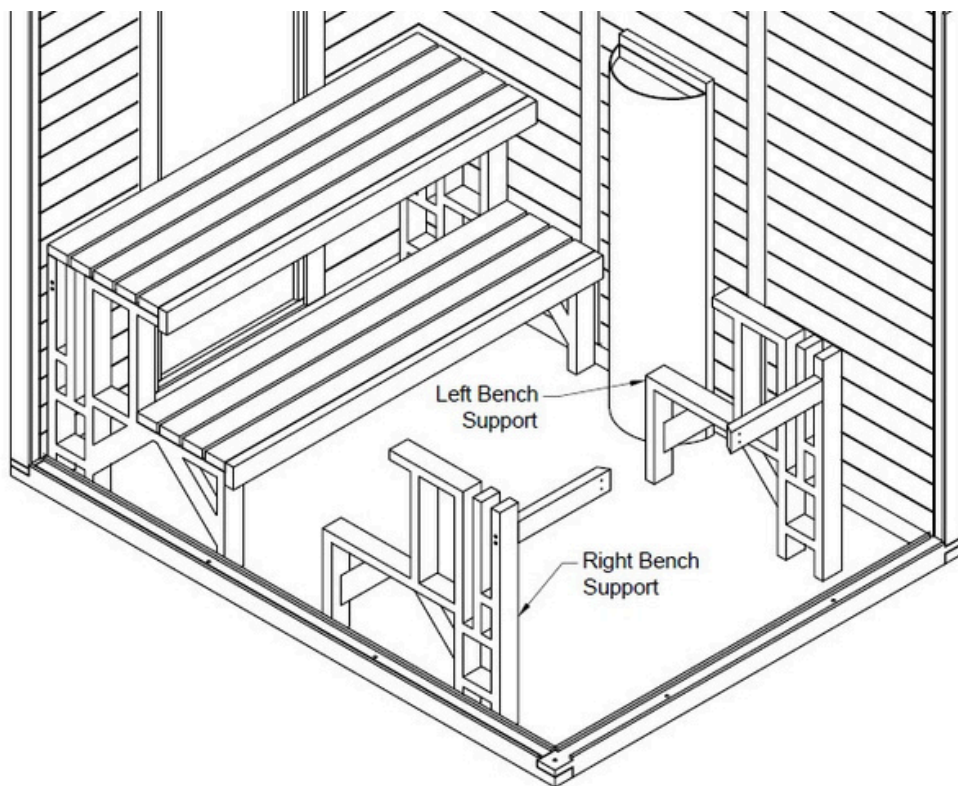

STEP 41

PLACE A BOTTOM BENCH ONTO THE SUPPORTS. USING A LEVEL, ADJUST THE LEVELING FEET ON THE SUPPORTS UNTIL THE BENCH IS LEVEL FROM LEFT TO RIGHT AND FRONT TO BACK.

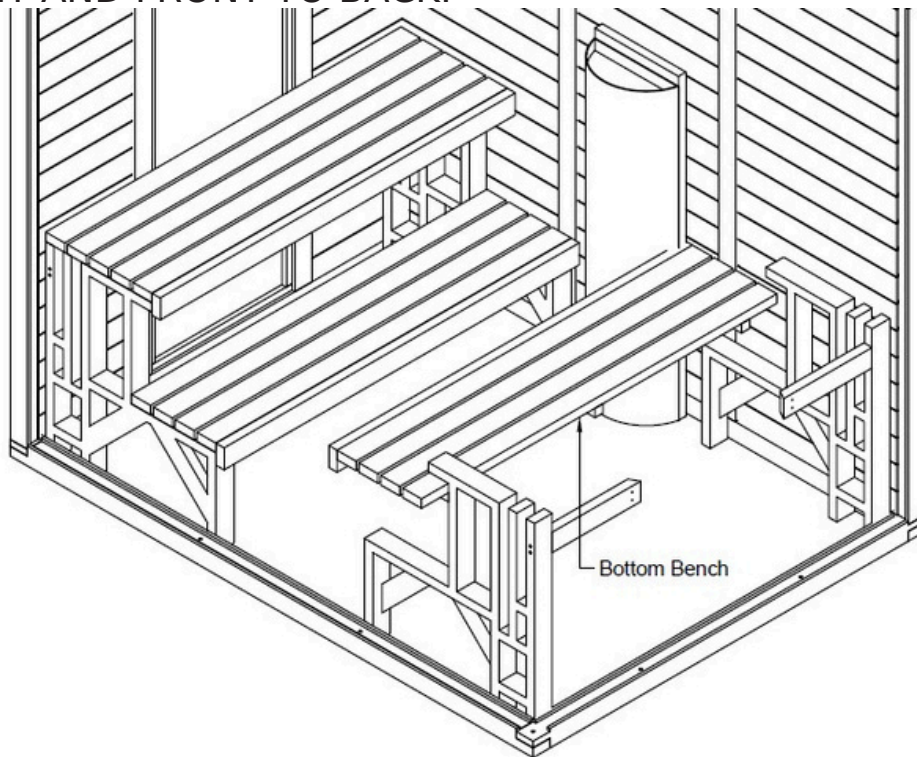

STEP 42

ONCE THE BENCH IS LEVELED, SCREW THE CROSS SUPPORTS INTO THE POSTS USING TWO 3" SCREWS ON EACH SIDE USING THE T25 TORX BIT.

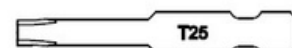
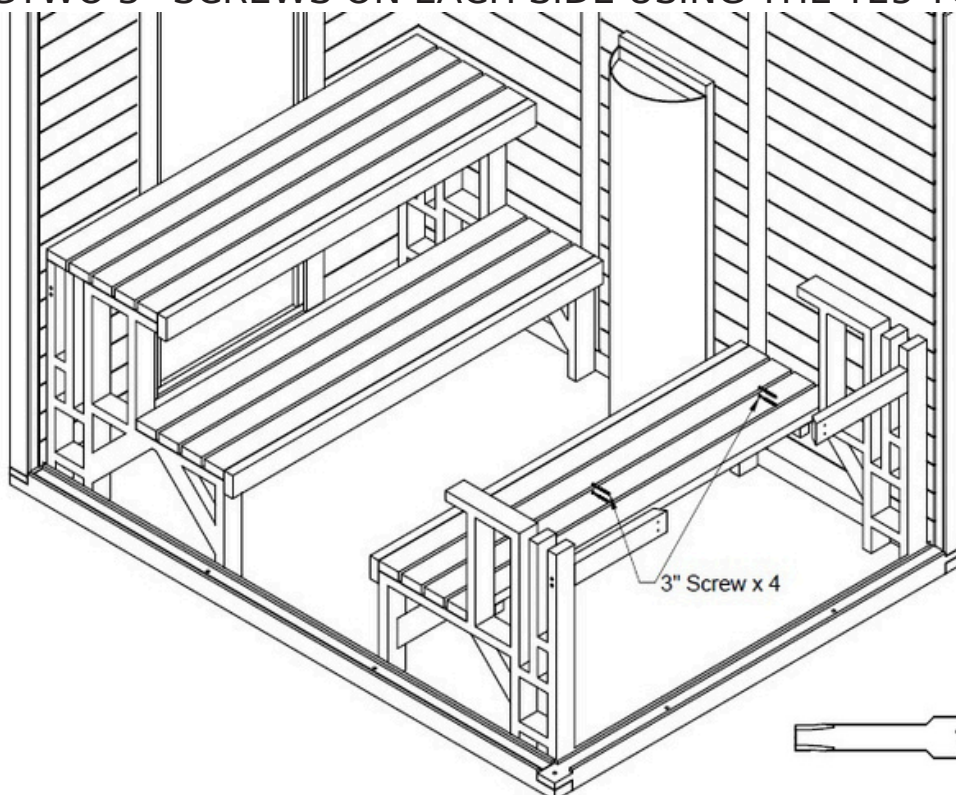

STEP 43

SLIDE TOP BENCH INTO POSITION.

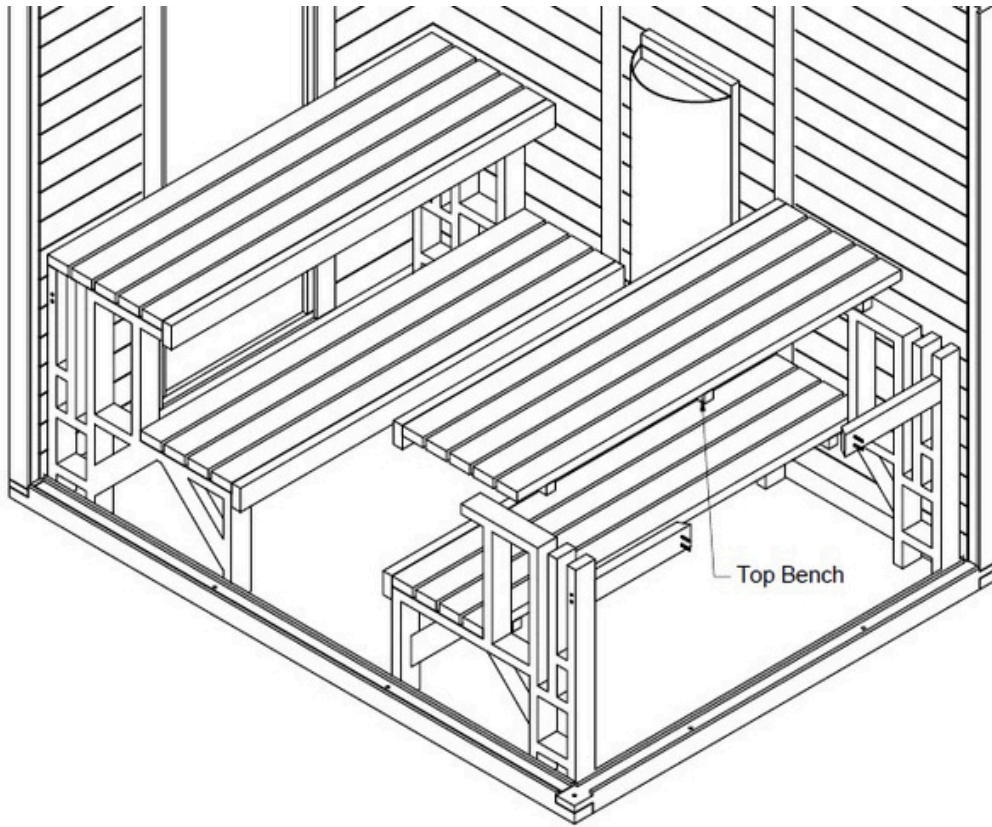

STEP 44

TO STORE THE BENCHES, SLIDE THE TOP BENCH INTO THE FRONT SLOT.

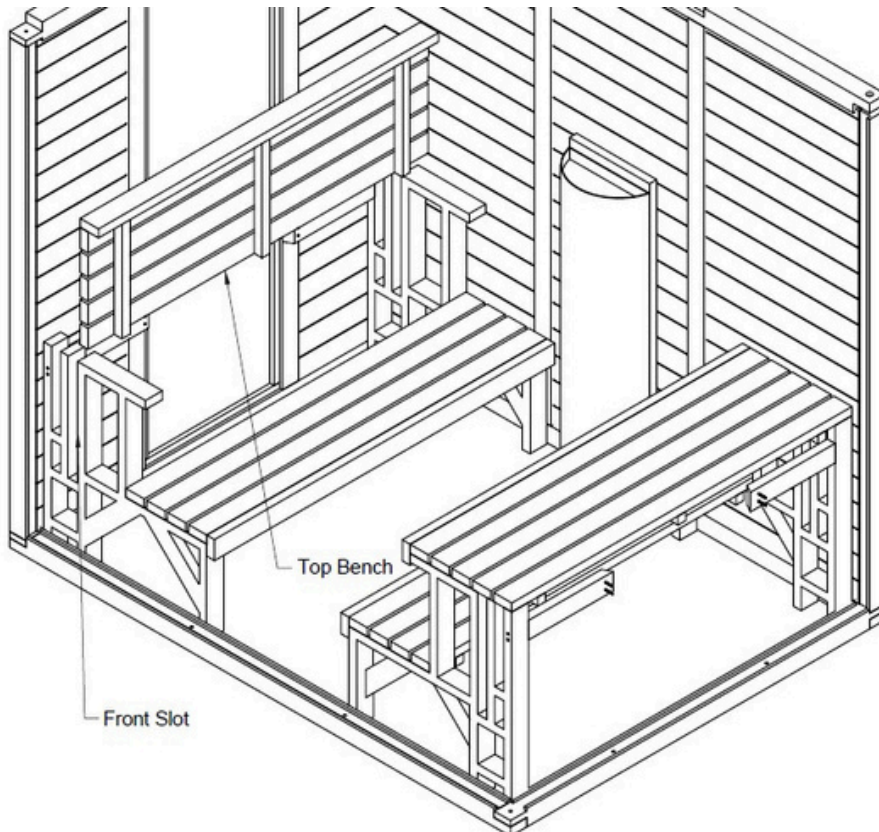

STEP 45

SLIDETHEBOTTOM BENCH INTO THE REAR SLOT. THEN REPEAT ON OTHER SIDE.

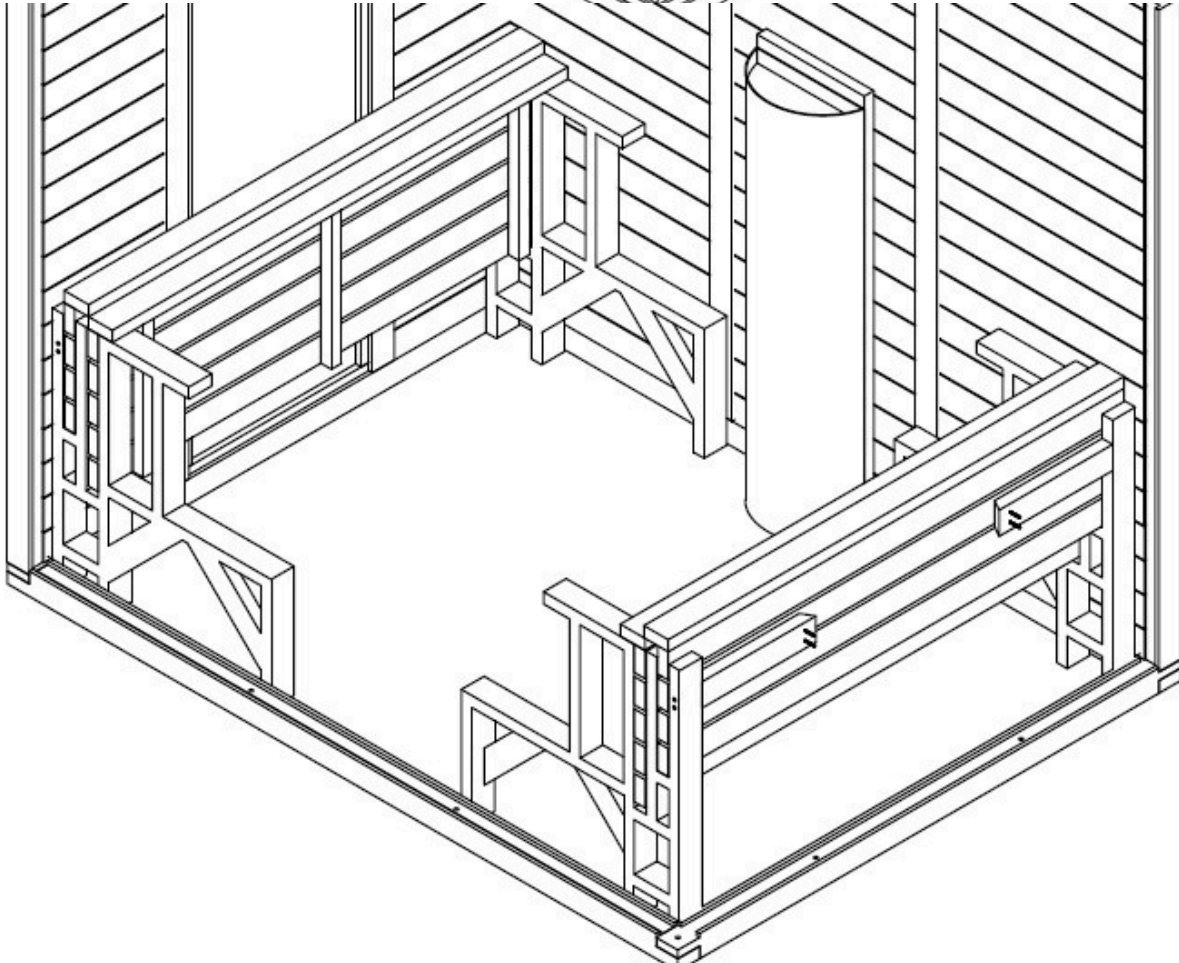
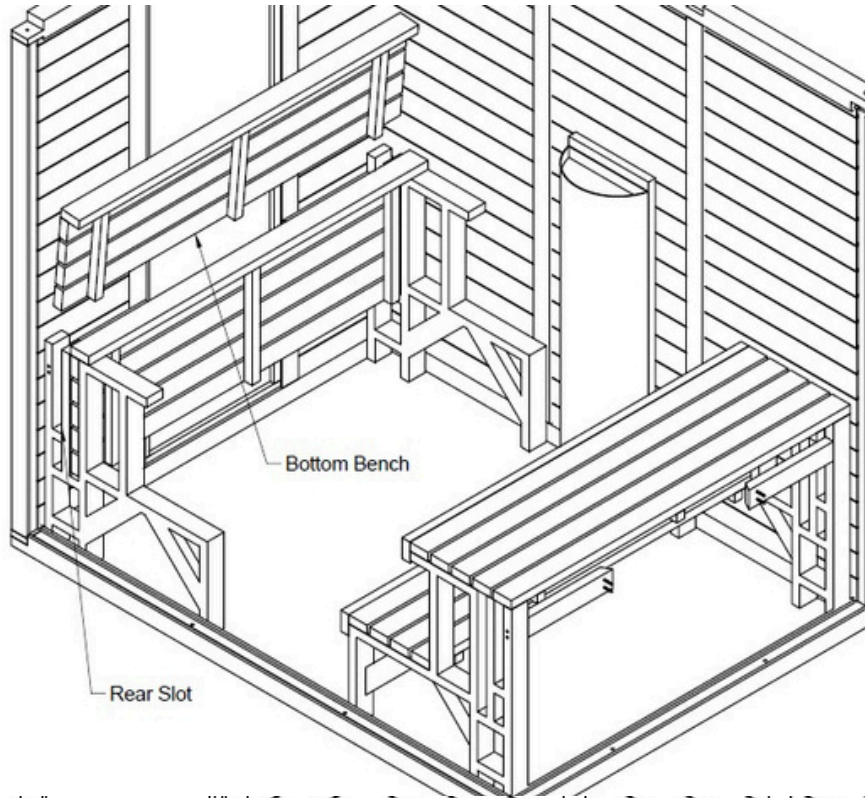

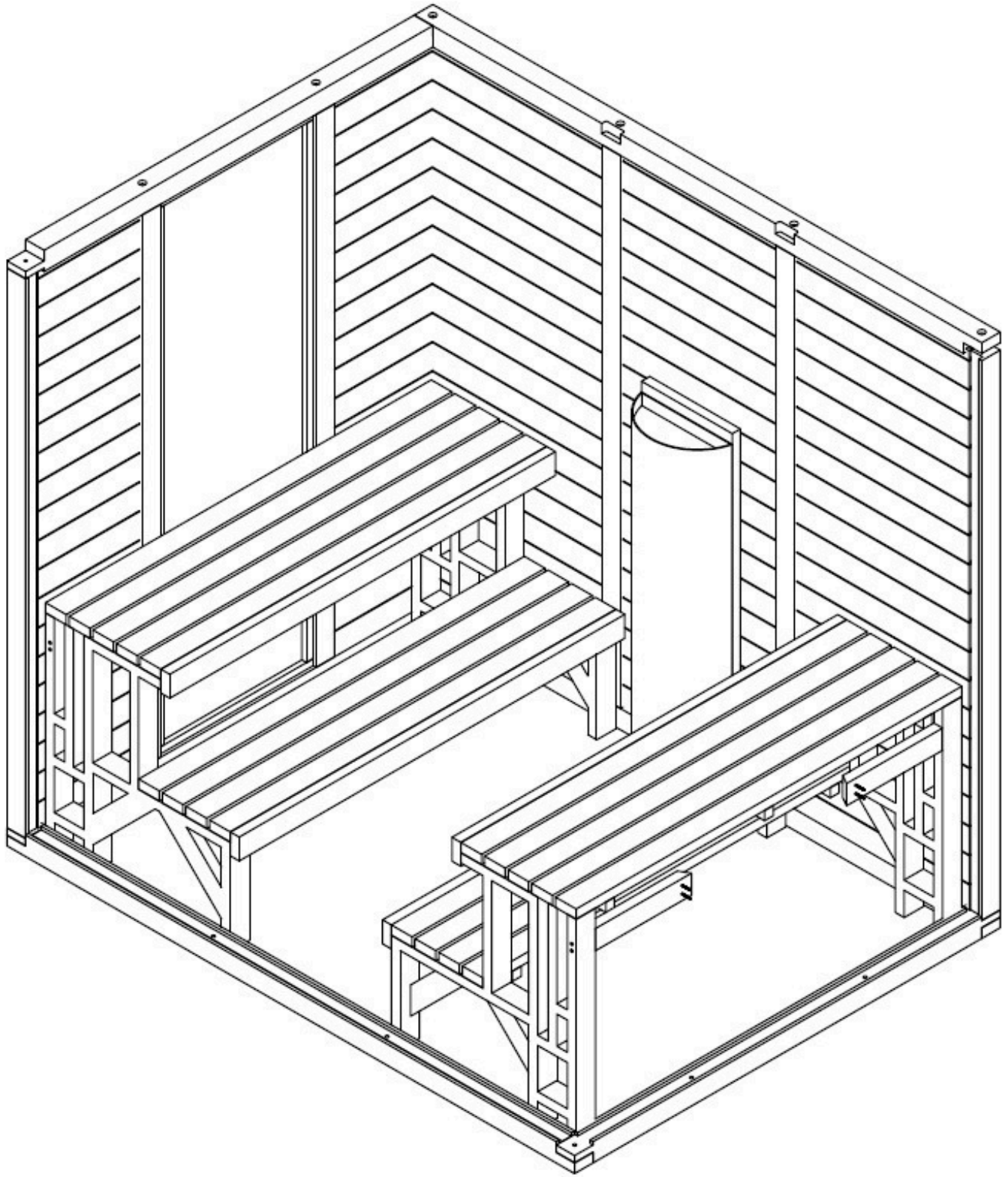

YOUR SAUNA SHOULD NOW BE FULLY ASSEMBLED AND READY TO ENJOY!

CONTACT US

FEEL FREE TO REACHOUT TO US WITH ANY QUESTIONS OR CONCERNS ABOUT THE INSTALLATION OR USE OF YOUR MOD6.